

Approved Accessories

TS 971 Industrial Door Control

▪ Connection Drawings

i NOTE

The manufacturer's instruction booklet supplied with the TS 971 control panel contains important directions and warnings for the safe use of this equipment, and should be read before installation or any commissioning is undertaken.

In accordance with BS EN 12453 self-checking or self-testing safety edge or a device certified as type 'E' according to BS EN 12453, i.e. light curtain fitted directly in line with the moving leaf of the door, must be fitted to doors that close by impulse, remote or automatic activation.

In addition, doors operated by untrained users in public areas, activated by impulse out of sight of the door or automatic control must be fitted with a one more photocells, to detect persons or obstacles standing on the floor to one side of the door.

The photocells do not need to be self-checking or self-testing but they should be subject to periodic checks at intervals not exceeding six months.

Grilles and doors that have hand or footholds that can be used to ride on the door must be fitted with devices to protect against trapping i.e. Raytector Entrapment Protection Barriers that when obstructed stop all movement of the door.

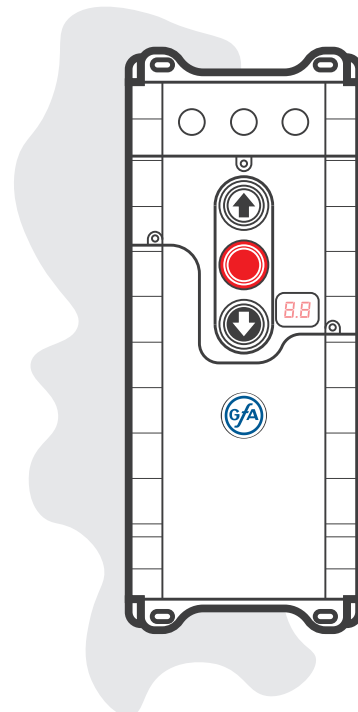

i NOTE

- A Maintenance Cycle Counter is included in the TS 971 (See Control Programming [B.5](#) and [B.6](#)).
- When commissioning the shutter, set the maintenance counter according to the shutter manufacturer's recommendations.

CONNECTION DRAWINGS FOR TS 971 SOFTWARE 3.1 and above.

- **IN ACCORDANCE WITH BS EN 12453.**

GfA ELEKTROMATEN Ltd
Agincourt Road
Warwick
CV34 6XZ

www.gfa-elektromaten.co.uk
technical@gfa-elektromaten.co.uk

01926 452 452

Explanation of Symbols

The following symbols are used in these instructions:

⚠ DANGER

Safety Note: Non-compliance will result in death or severe injury

⚠ WARNING

Safety Note: Non-compliance can result in death or severe injury

⚠ CAUTION

Safety Note: Non-compliance can result in injury

NOTICE

Note: Non-compliance can result in material damage and impairment of product functionality

i NOTE

Note: Points out useful additional information

Intended Use

The door control is intended for installation in a force-actuated door with a GfA limit switch system. The drive unit must be protected against moisture and aggressive environmental conditions (such as corrosive substances). The drive units are only suitable for indoor use. Appropriate protective measures must be taken for outdoor installation. The drive unit is not intended for hazardous areas. The values specified in the technical data of the drive unit must not be exceeded. The safe operation can only be ensured if used as specified.

Target Audience of these Instructions

As a user or operator, contact the manufacturer for your door system. These connection instructions are geared towards qualified persons trained in the handling of door systems. Expert knowledge, relevant skills and practical experience are what set apart qualified persons. They are capable of safely carrying out the tasks involving, maintenance and modernisation according to the TS 971 installation instructions.

A trained electrician must carry out the electrical installation. Trained electricians meet the following requirements:

- They are familiar with the applicable safety and accident prevention regulations.
- They recognise hazards relating to electricity and the door control and take safety precautions.

Electrical Installation and Connecting External Devices

⚠ WARNING

Danger to life from electric shock!

Improper wiring may result in severe or fatal injury from electrical shock.

- Allow only competent or skilled persons to carry out the work.
- Follow safe isolation procedures on the power source.
- Observe valid regulations and standards.
- Use suitable tools.
- Ensure all equipment is selected and installed suitably for the environment and intended use.

General Setup

Connection of Drive Unit to Control Panel (Digital Limits).....	4 - 5
Mains Supply - Three-Phase Door Drives.....	6
Mains Supply - Single-Phase Door Drives.....	7
Safety Brake - Connection to Drive Unit.....	8 - 9

Operational Control

Pairing of VR/K2E Wireless Keypad.....	10
Built-in Radio Receiver and Pairing Radio Transmitters.....	11
Connecting VR/XPL5 Multi-User Receiver.....	12
Loop Detector and Ground Loop(s).....	13 - 14
Latching Emergency Stop Button.....	15
Access Control Devices.....	16 - 19

Safety Sensors

2No. PES/30T Photocells (Through-Beam).....	20
1No. PES/30T Photocells (Through-Beam).....	21
2No. PES/9R Photocells (Polarised Reflective).....	22
1No. PES/9R Photocells (Polarised Reflective).....	23
2No. PES/4.5TOF/POT (Time-of-Flight Photocells).....	24
1No. PES/4.5TOF/POT (Time-of-Flight Photocell).....	25
BS EN 12453 - Minimum Levels of Safeguarding.....	26
KSR4P Wired Safety Edge Connections.....	27 - 29
KSR6 Wireless Safety Edge.....	30 - 31
GF304528 Raytector High Level Entrapment Protection Barrier.....	32
KGF/RAY-LG2520/OSE and KGF/RAY-LG2524/OSE Light Curtains.....	33
(2x) KGF/RAY-LG25XX/OSE Light Curtains.....	34
(1x) KGF/RAY-LG25XX/OSE Light Curtains and KSR 6 Wireless Safety Edge Box.....	35

Traffic Lights

230VAC Warning Light.....	36
GF301955 - Red and Green Traffic Indicator.....	37
JE419130 - Red and Green Traffic Indicator (24VDC Traffic Lights).....	38
JE419130 - Red and Green Traffic Indicator (230VAC Traffic Lights).....	39

Motion / Presence Sensors

1No. LZR Widescan with auxiliary PSU.....	40
1No. LZR100 and 110 Laser Safety Sensor with auxiliary PSU.....	41
2No. LZR100 and 110 Laser Safety Sensor with auxiliary PSU.....	42 - 43
1No. Condor and Condor XL.....	44
1No. Falcon and Falcon XL.....	45

Power Supplies

Power Supply for Control Accessories.....	46
Power Supplies Available.....	47

Special Connections

Interlocking 2No. TS 971 Control Panels.....	48
New Control with previous version KSR4P Optical Wired Safety Edge.....	49

Connection of drive unit to control panel

▪ Digital Limits

Motor Cable

PIN	Wire - No.	Description
1	3	Phase W
2	2	Phase V
3	1	Phase U
4	4	Neutral
5	PE	Earth

DES Cable

PIN	Wire - No.	Description
1	5	Safety Circuit 24VDC
2	6	(RS485) Channel B
3	7	Ground
4	8	(RS485) Channel A
5	9	Safety Circuit
6	10	Supply Voltage 8VDC

NOTE

THE DES 3.2, DES 4.0 AND DES 10 ARE ALL INTERCHANGEABLY COMPATIBLE.

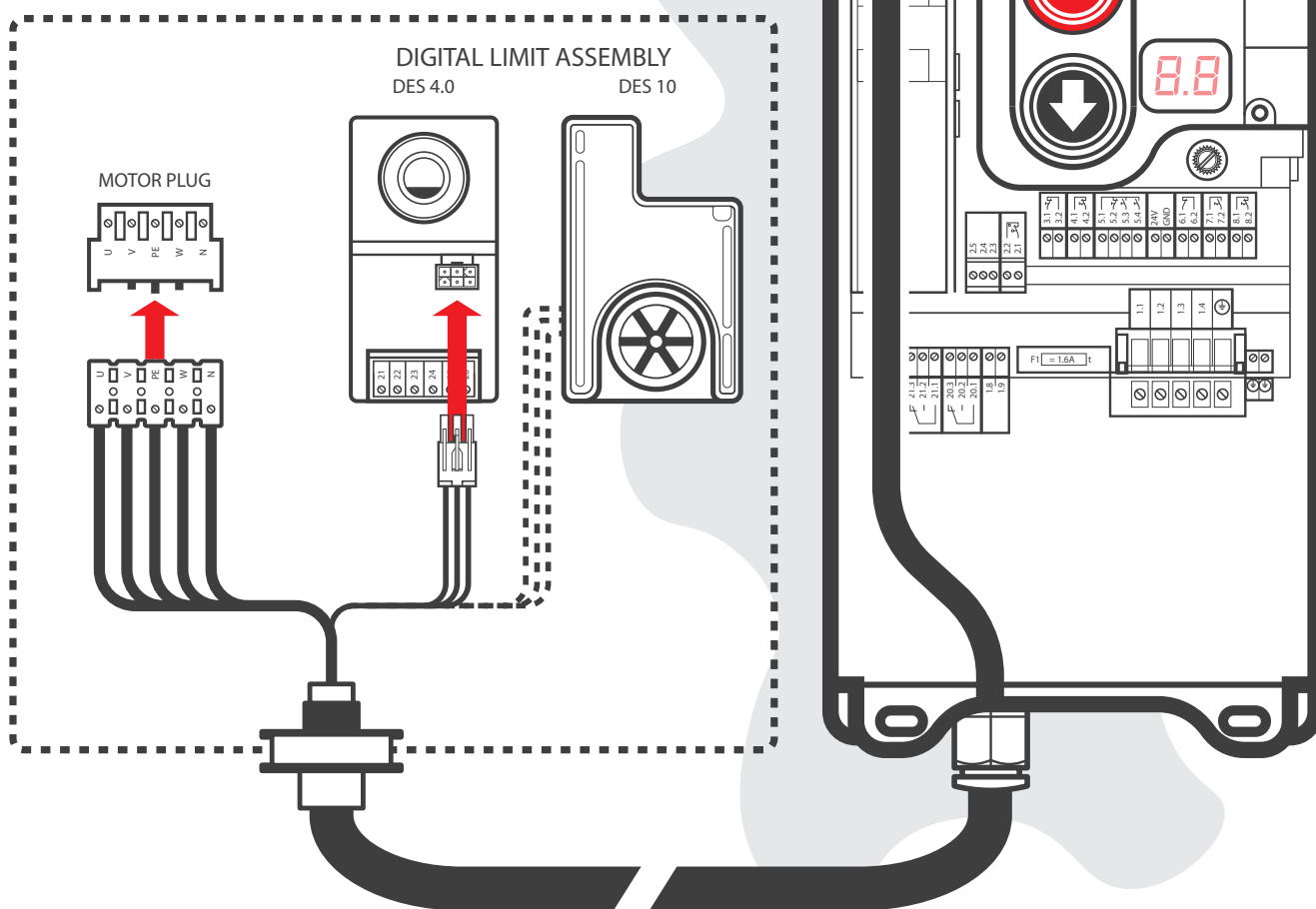

NOTICE

Damage to components!

The motor / limit protected cable set should not be cut. Please use GfA supplied motor and limit cable adaptor boxes for cable extensions and modifications.

The Motor / Limit protected cable is available in 1.5m, 3m, 5m, 7m, 9m, 13m and custom lengths up to 50m. The Motor / Limit cable **must not** exceed 50m.

▪ Digital Limits

Motor Cable

PIN	Wire - No.	Description
1	3	Phase W
2	2	Phase V
3	1	Phase U
4	4	Neutral
5	PE	Earth

DES Cable

PIN	Wire - No.	Description
1	5	Safety Circuit 24V DC
2	6	RS485 B
3	7	GND
4	8	RS485 A
5	9	Safety Circuit
6	10	8V DC

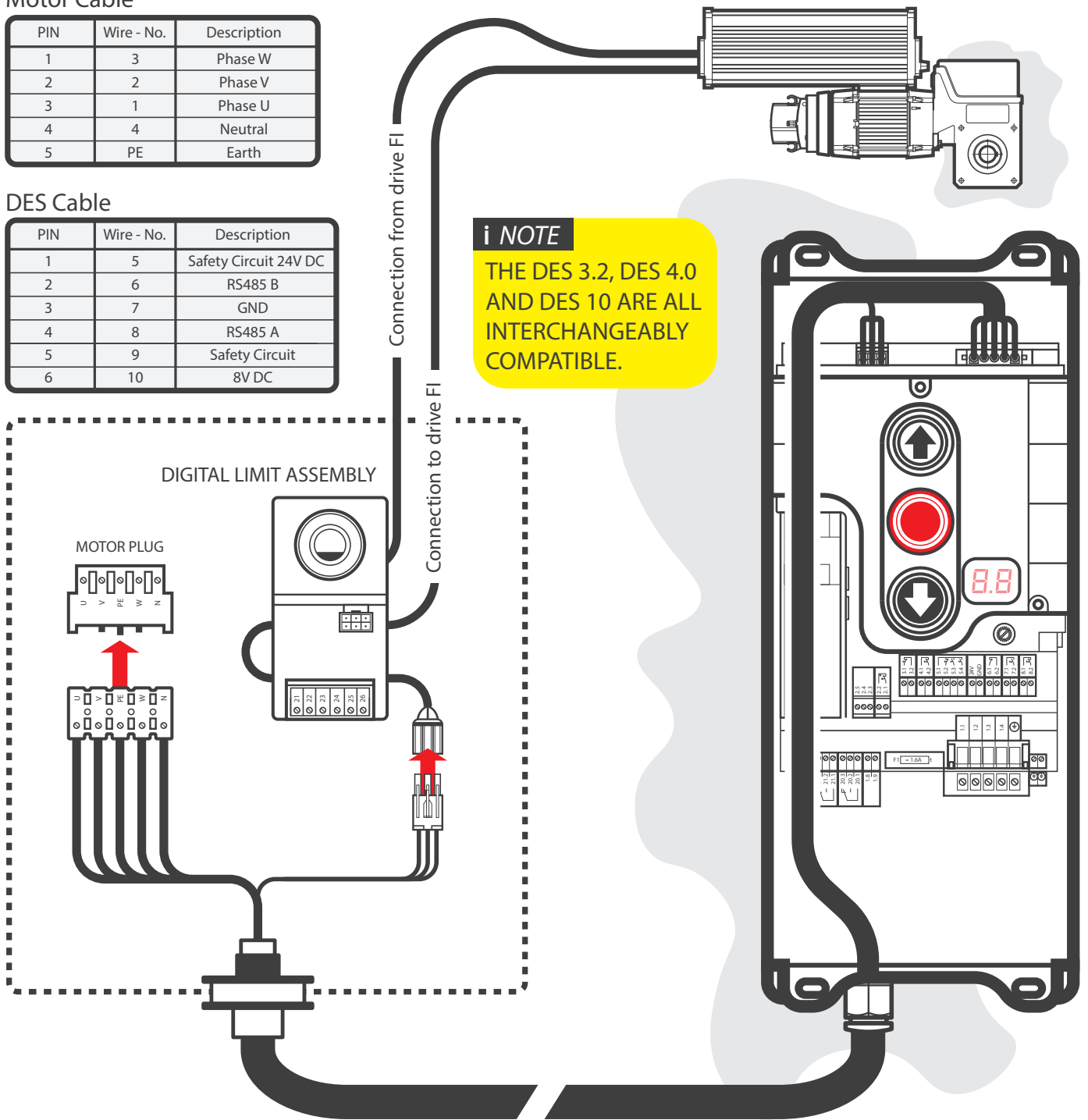

NOTICE

Damage to components!

The motor / limit protected cable set should not be cut. Please use GfA supplied motor and limit cable adaptor boxes for cable extensions and modifications.

The Motor / Limit protected cable is available in 1.5m, 3m, 5m, 7m, 9m, 13m and custom lengths up to 50m. The Motor / Limit cable **must not** exceed 50m.

Mains Supply

▪ Three-Phase Door Drives

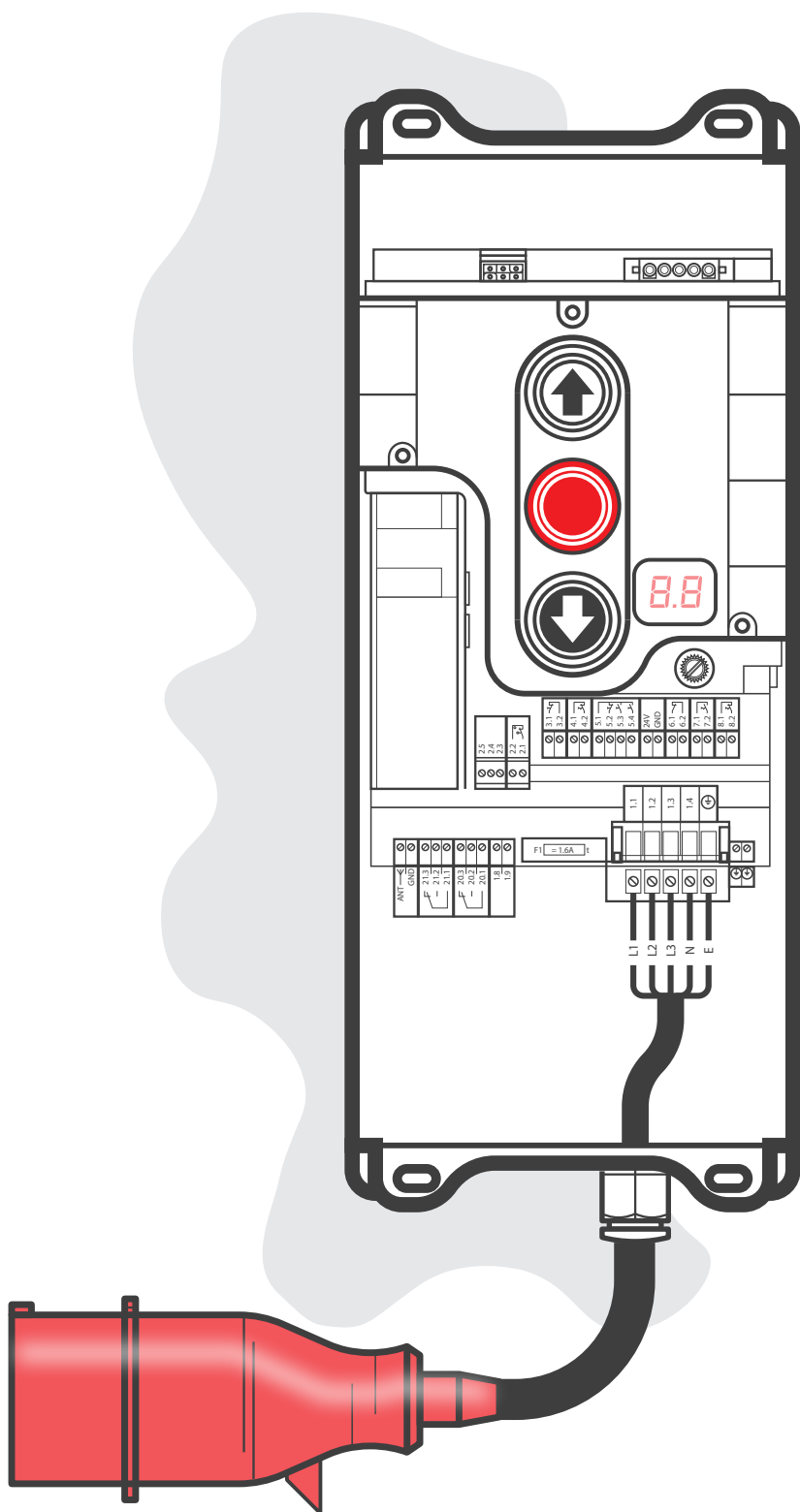

⚠ WARNING

- **Danger to life from electric shock!**
- Improper wiring may result in severe or fatal injury from electrical shock.
- Allow only competent or skilled persons to carry out the work.
- Follow safe isolation procedures on the power source.
- Observe valid regulations and standards.
- Use suitable tools.
- Ensure all equipment is selected and installed suitably for the environment and intended use.

i NOTE

- L1 ▪ Black
- L2 ▪ Brown
- L3 ▪ Grey
- N ▪ Blue
- E ▪ Green / Yellow

i NOTE

A neutral is only required for FI drives or if 1~ 230VAC control accessories or indicator lamps are installed.

Mains Supply

▪ Single-Phase Door Drives

i NOTE

There are two types of single-phase motor windings:

- Symmetric
- Asymmetric

To determine how to connect the supply, look at the motor connection plug in the motor limit housing.

⚠ WARNING

- **Danger to life from electric shock!**
- Improper wiring may result in severe or fatal injury from electrical shock.
- Allow only competent or skilled persons to carry out the work.
- Follow safe isolation procedures on the power source.
- Observe valid regulations and standards.
- Use suitable tools.
- Ensure all equipment is selected and installed suitably for the environment and intended use.

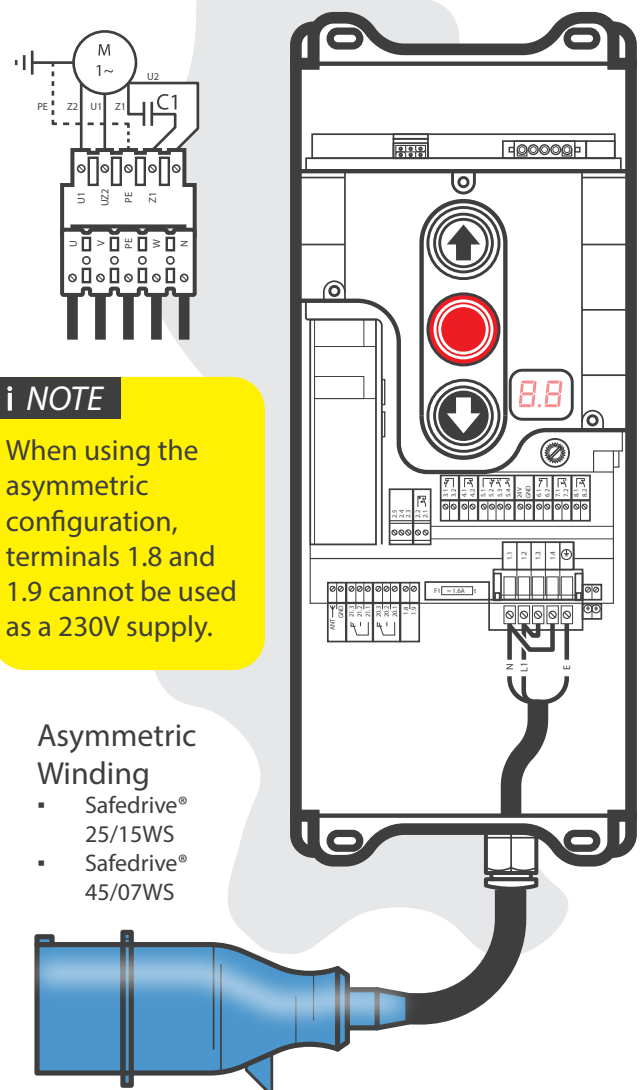
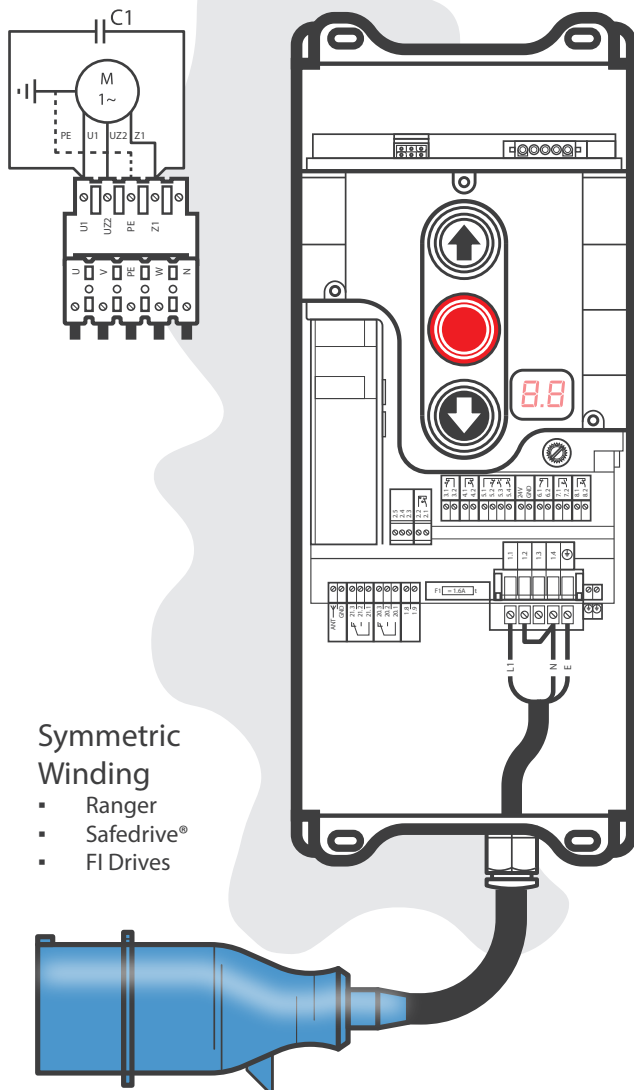

i NOTE
When using the asymmetric configuration, terminals 1.8 and 1.9 cannot be used as a 230V supply.

Safety Brake



▪ Connection to Drive Unit (DES 3.0, 3.2 & 4.0)

i NOTE

The connections below can also be set on a spring break device for a sectional door.

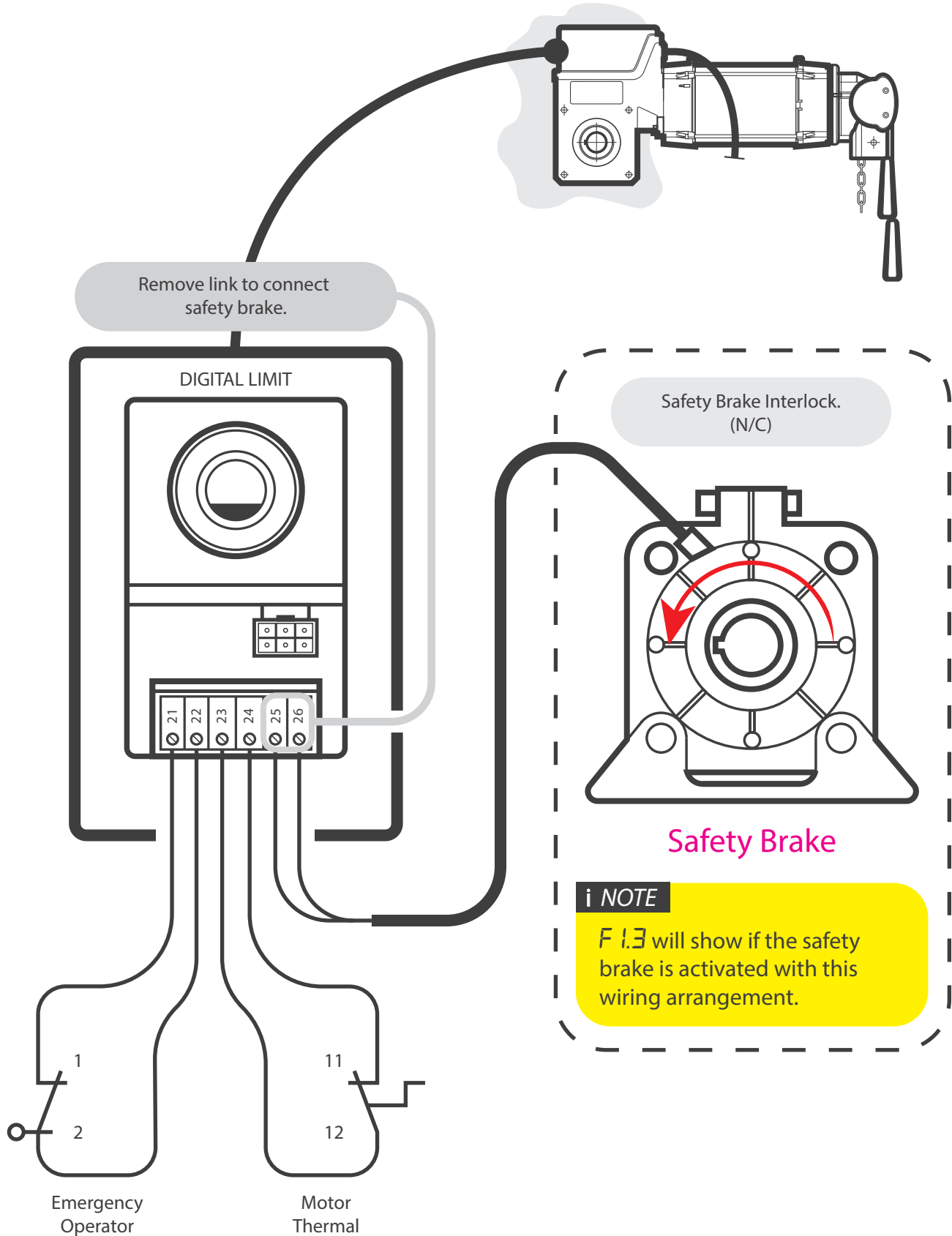

Safety Brake

▪ Connection to Drive Unit (DES 10)

i NOTE

The connections below can also be set on a spring break device for a sectional door.

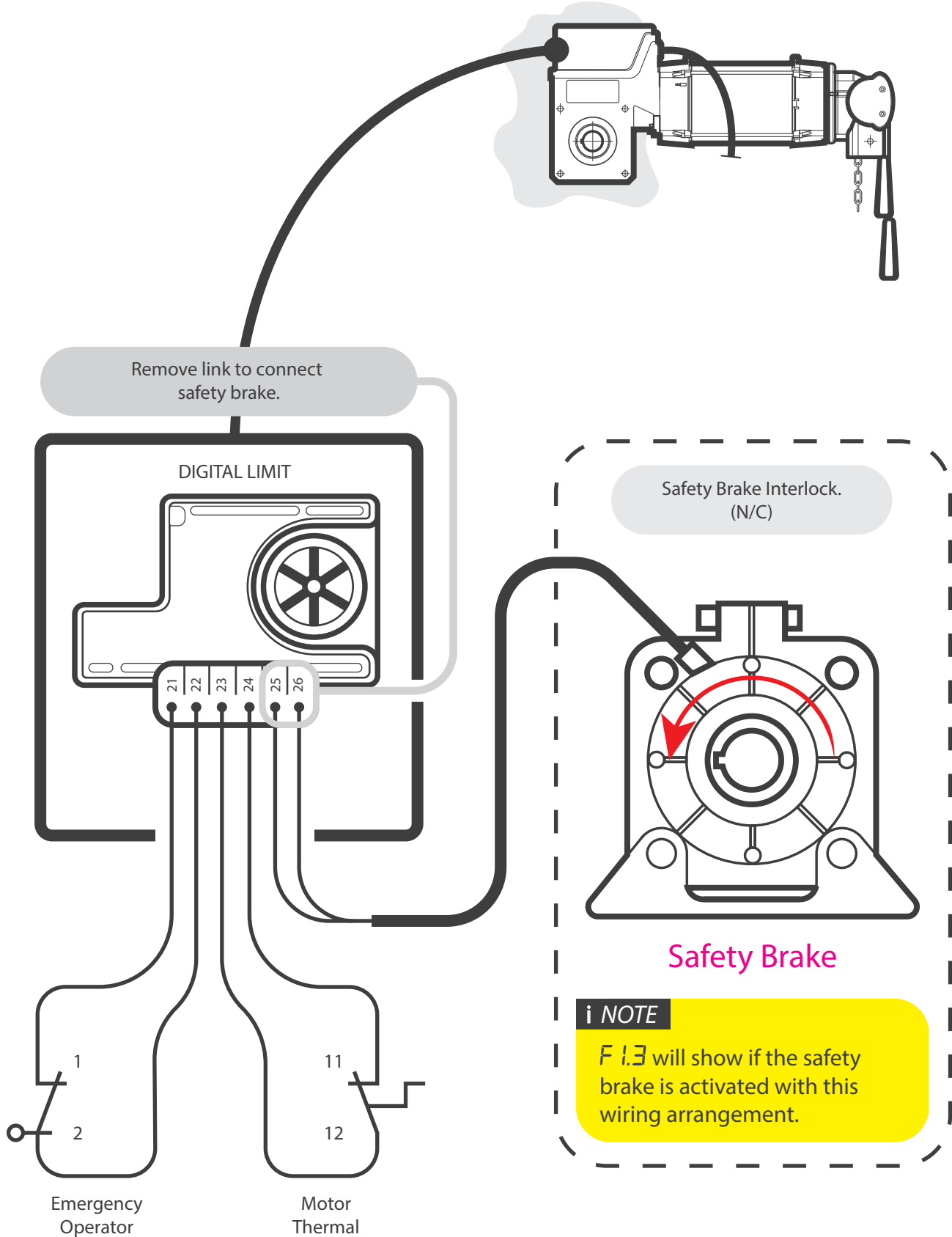

Pairing VR/K2E

▪ Wireless Keypad

i NOTE

Consult the VR/K2E installation instructions for full guidance and safety information.

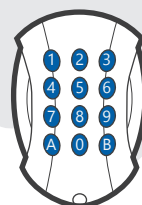

VR/K2E
Wireless
Keypad

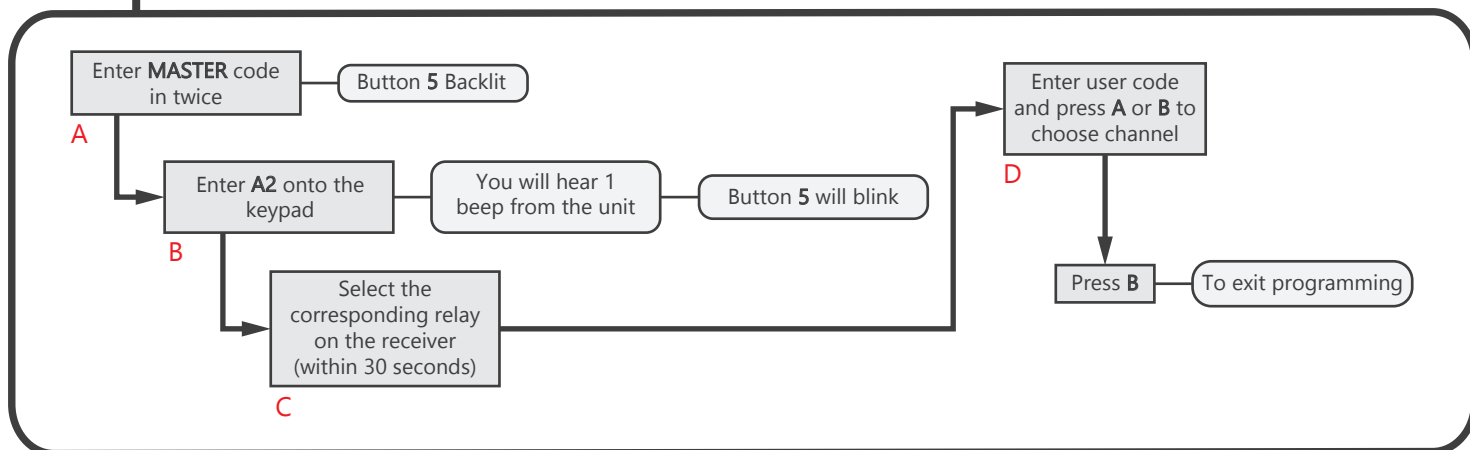
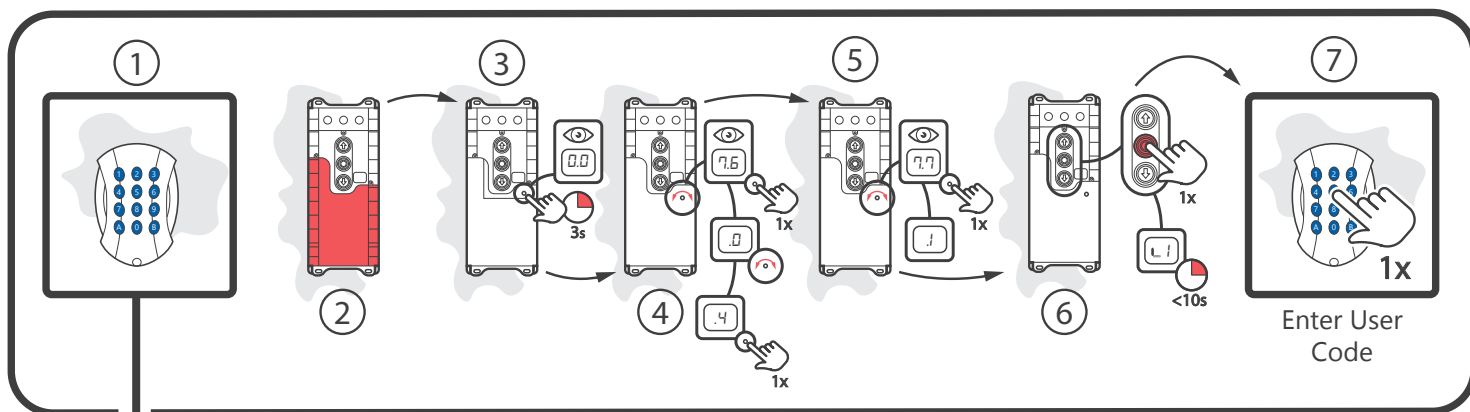
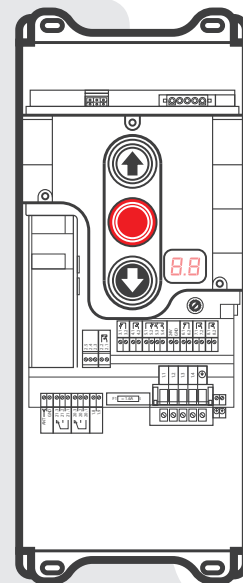

i NOTE

Consult the VR/K2E installation instructions for full guidance on setting or changing user codes and master codes.

Built-in Radio Receiver

▪ Pairing Radio Transmitters

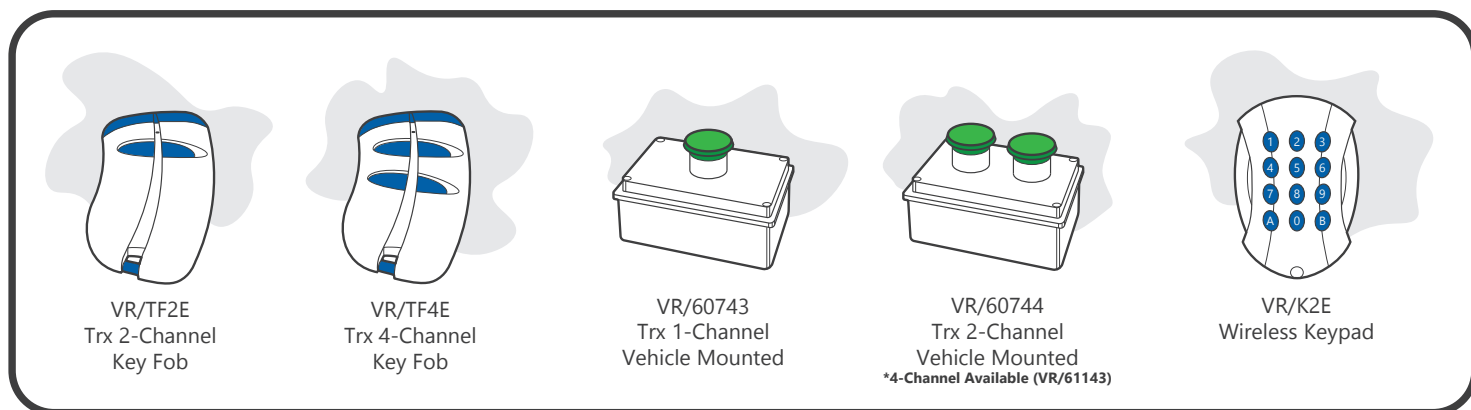

Before pairing any GfA remote transmitters, parameter **7.6** should be set to **.4** to instruct the TS 971 to receive GfA Rolling Code Transmitters.

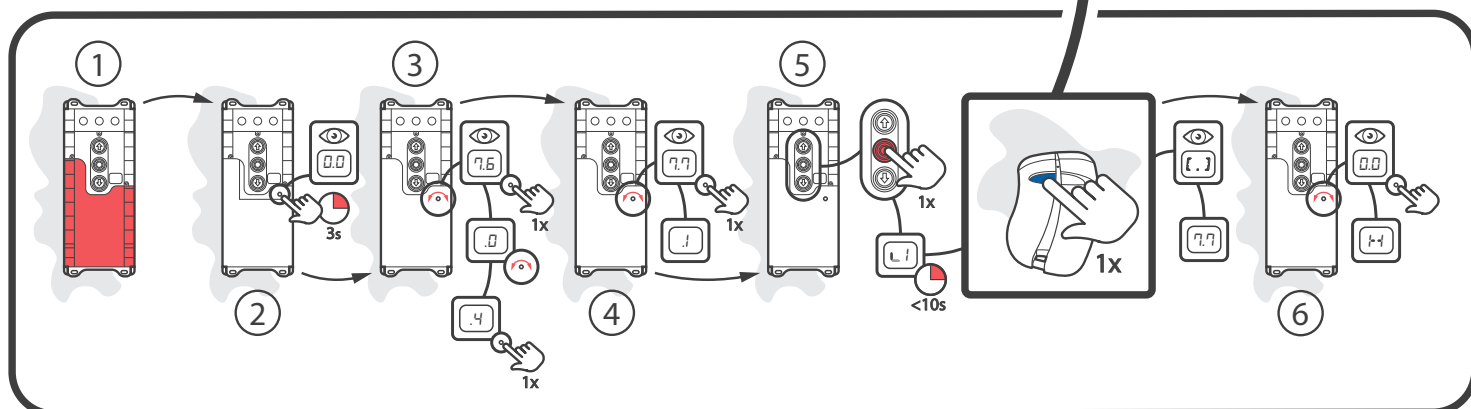

To pair each transmitter, select parameter **7.7** and press the STOP button when **.1** is present on the TS 971 display. Within 10 seconds of this, press the transmitter button you wish to pair to the door controller.

i NOTE

TS 971 in-built radio receiver can pair up to 64 transmitters.

Connecting VR/XPL5 Multi-User Receiver



External Radio Receiver Connection

i NOTE

XPL5 has a capacity of 500 remote fobs.

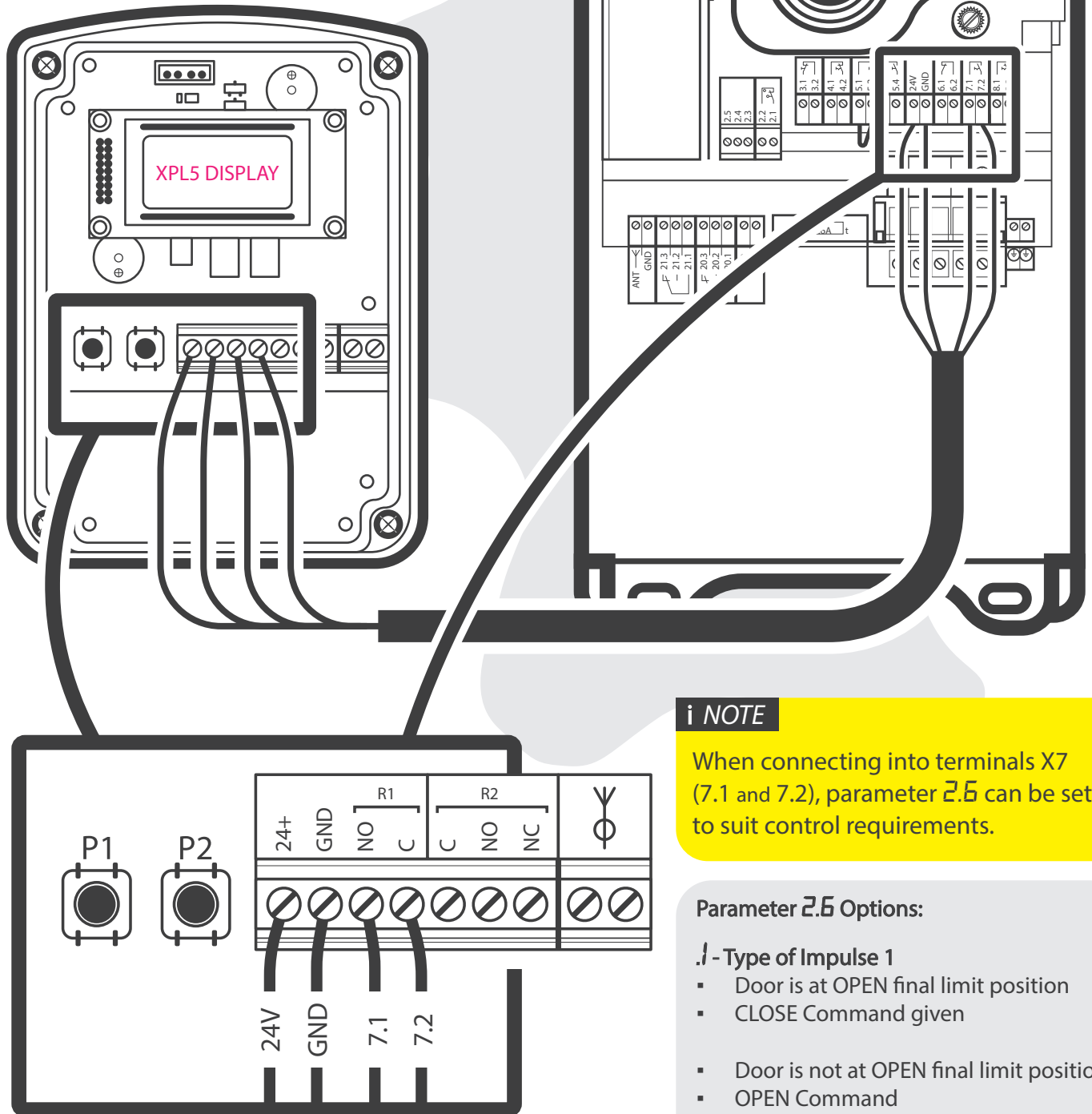

i NOTE

When connecting into terminals X7 (7.1 and 7.2), parameter 2.5 can be set to suit control requirements.

Parameter 2.5 Options:

.1 - Type of Impulse 1

- Door is at OPEN final limit position
- CLOSE Command given

- Door is not at OPEN final limit position
- OPEN Command

.2 - Type of Impulse 2

- Command Sequence
- OPEN - STOP - CLOSE - STOP - OPEN

.3 - Type of Impulse 3

- OPEN Command ONLY

i NOTE

Alternative wiring arrangement.

- X5 (5.1 and 5.3) - OPEN command **ONLY**.

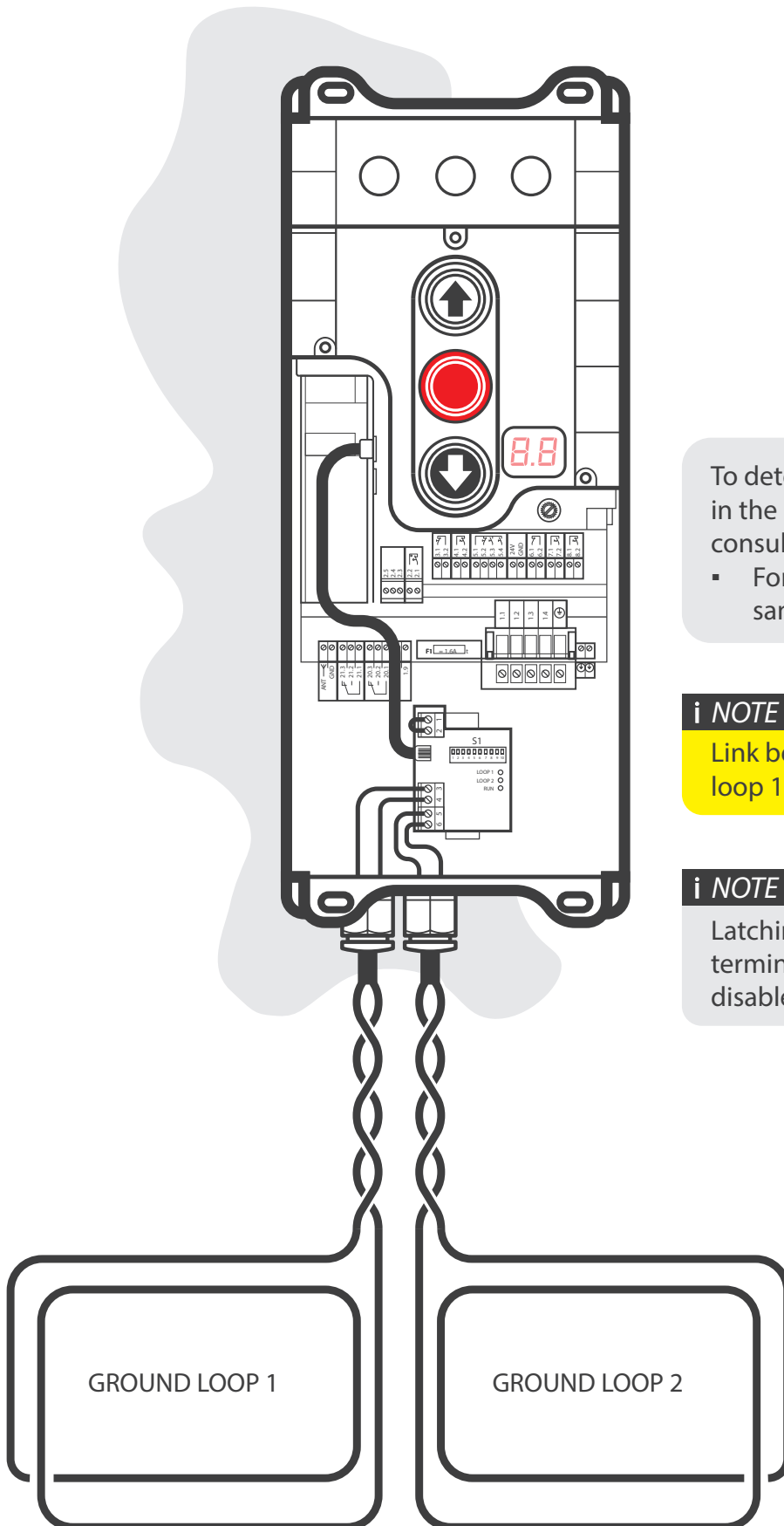

To determine the number of turns of cable in the ground loop and settings, please consult the Loop Detector instructions.

- For existing loops, replace with the same loop detector.

i NOTE
Link between 1 and 2 is used to turn OFF loop 1 when removed.

i NOTE
Latching button can be connected via terminals 1 and 2 on the loop card to disable loop 1.

The 'RUN' LED will light up after being switched on. At this time the LED's of 'Loop1' and 'Loop2' will be flashing.

- Flashing indicates the initialisation of loops.

Loop 1 always generates an OPEN command that may be switched off with an external break contact, for example with a time switch in Terminals 1 and 2 on the loop card.

DIP switches 1 and 2 allow adjustment of 'Loop 2':

- Only one may be set to ON. For direction detection, both DIP switches must be set to OFF.
- If both DIP switch 1 and 2 are set to ON, E1.2 will display on the TS control panel.

1	LOOP 2 generates an OPEN command (DIP switch 2 MUST be OFF)							
2	LOOP 2 generates a CLOSE command (DIP switch 1 MUST be OFF)							
3	Frequency Change To prevent interference between adjacent loops and other systems							
Sensitivity Settings								
4 - 7	Loop 1				Loop 2			
	4		5		6		7	
	ON	+	ON	HIGH	ON	+	ON	HIGH
	ON	+	OFF	MED	ON	+	OFF	MED
	OFF	+	ON	LOW	OFF	+	ON	LOW
	OFF	+	OFF	OFF	OFF	+	OFF	OFF
8	Function Boost For better detection of vehicles with high ground clearance (lorries)							
9	Function of Direction Detection (1 + 2 = OFF + OFF) An OPEN command is generated immediately when crossing loop 1 without crossing loop 2 first. In reverse order no command is given							
10	Function of Direction Detection (1 + 2 = OFF + OFF) An OPEN command is generated only if loop 1 is crossed first and then loop 2. In reverse order no command is given							

i NOTE

F 1.4 will show if the Emergency Stop is activated.

i NOTE

In the case of a drive unit with a frequency inverter, the door control can only be operated again after 30 seconds after the emergency stop switch has been unlocked. Meanwhile, the gate control display flashes.

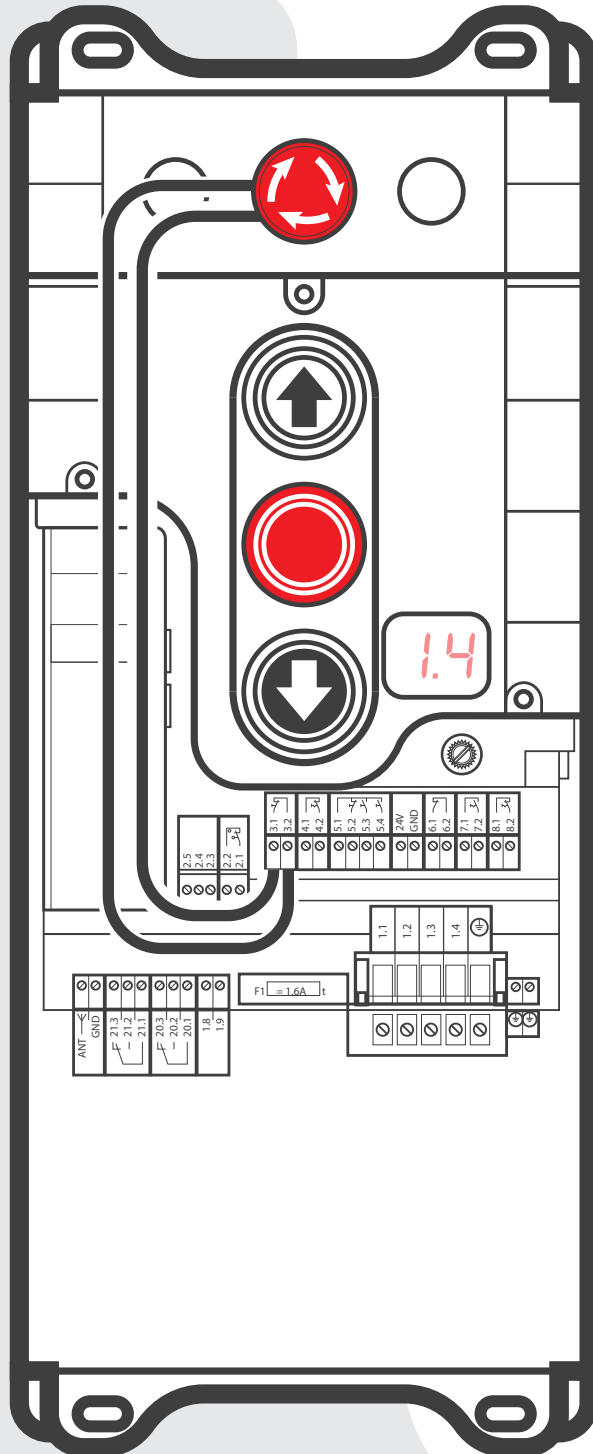

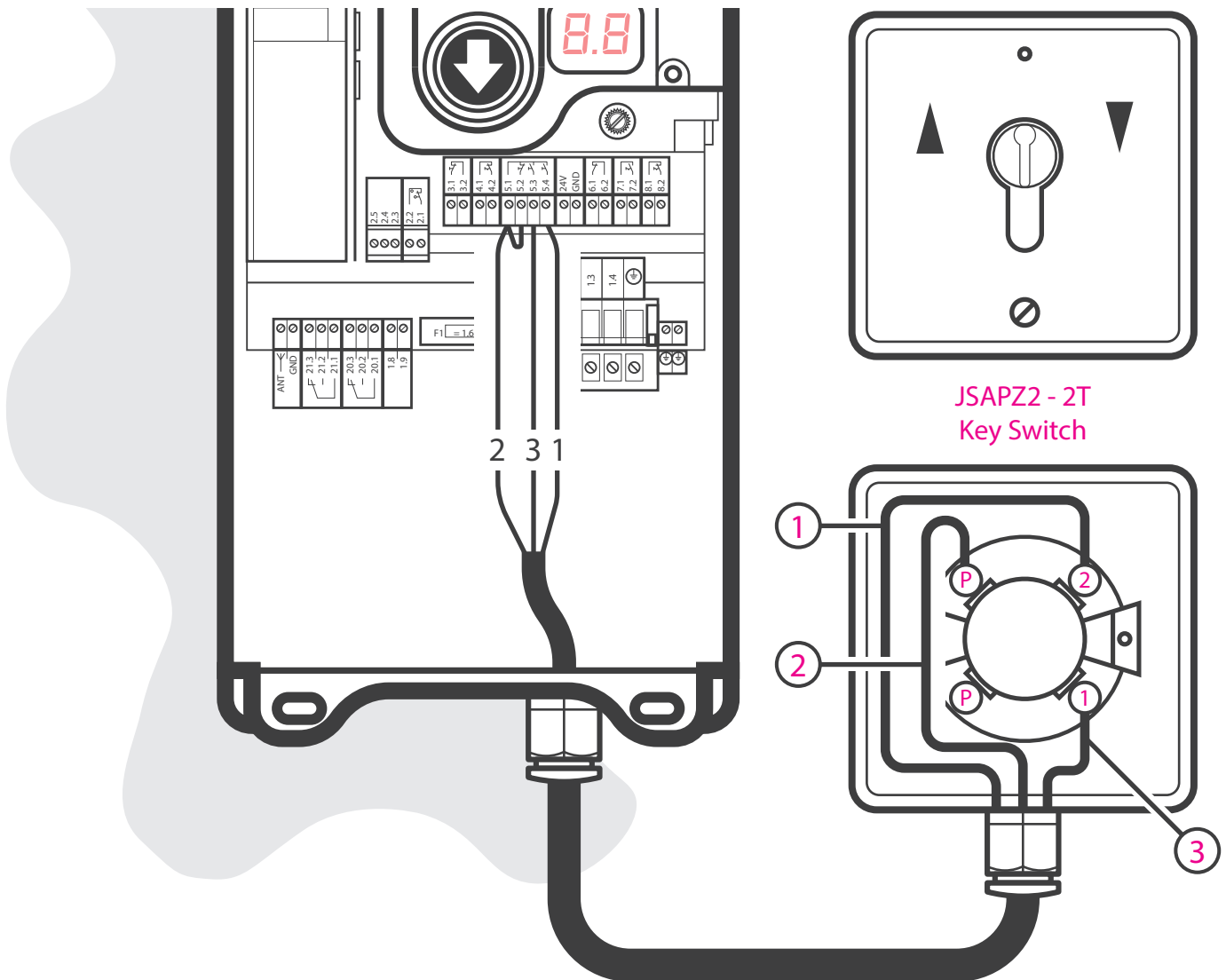

⚠ WARNING

Danger due to unattended door movement!

The safety devices are deactivated in operating mode hold-to-run. People or objects in the movement path are not detected.

- Install and operate the control device with a clear view of the door.

The Key Switch must be in clear view of the door, and should be operated by trained users ONLY, or a photocell and safety edge must be fitted to detect persons or obstacles standing on the floor to one side of the door.

Latching Stop Push Buttons are recommended for all doors that can be started remotely or automatically by vehicles approaching the door.

- See page 15 for instructions on fitting a Latching Stop Push Button.

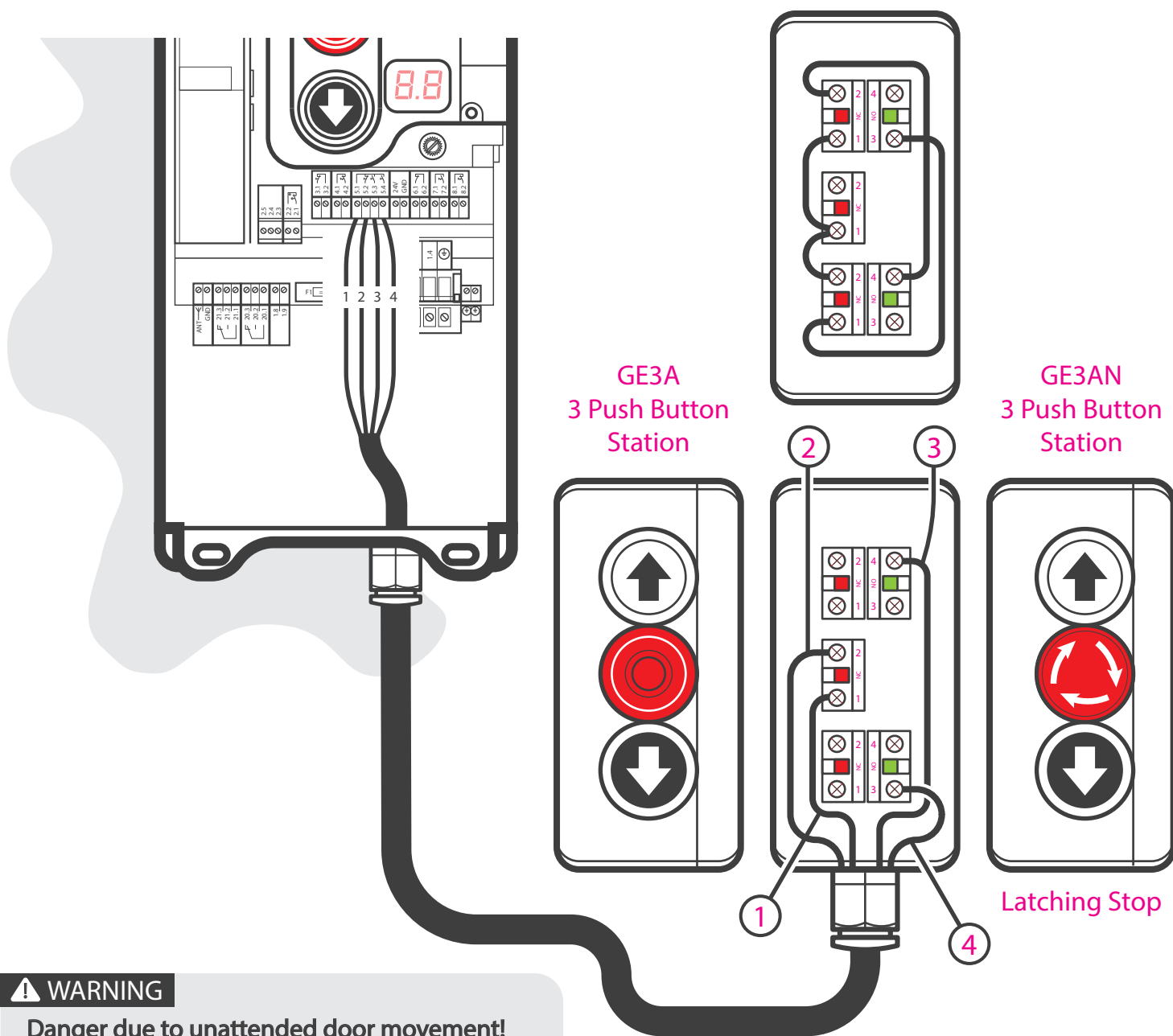

⚠ WARNING
Danger due to unattended door movement!
 The safety devices are deactivated in operating mode hold-to-run. People or objects in the movement path are not detected.

- Install and operate the control device with a clear view of the door.

The Push Button Station must be in clear view of the door, and should be operated by trained users ONLY, or a photocell and safety edge must be fitted to detect persons or obstacles standing on the floor to one side of the door.

Latching Stop Push Buttons are recommended for all doors that can be started remotely or automatically by vehicles approaching the door.

- See page 15 for instructions on fitting a Latching Stop Push Button.

Connecting a JAPZ4 - 1R

- As Supplied

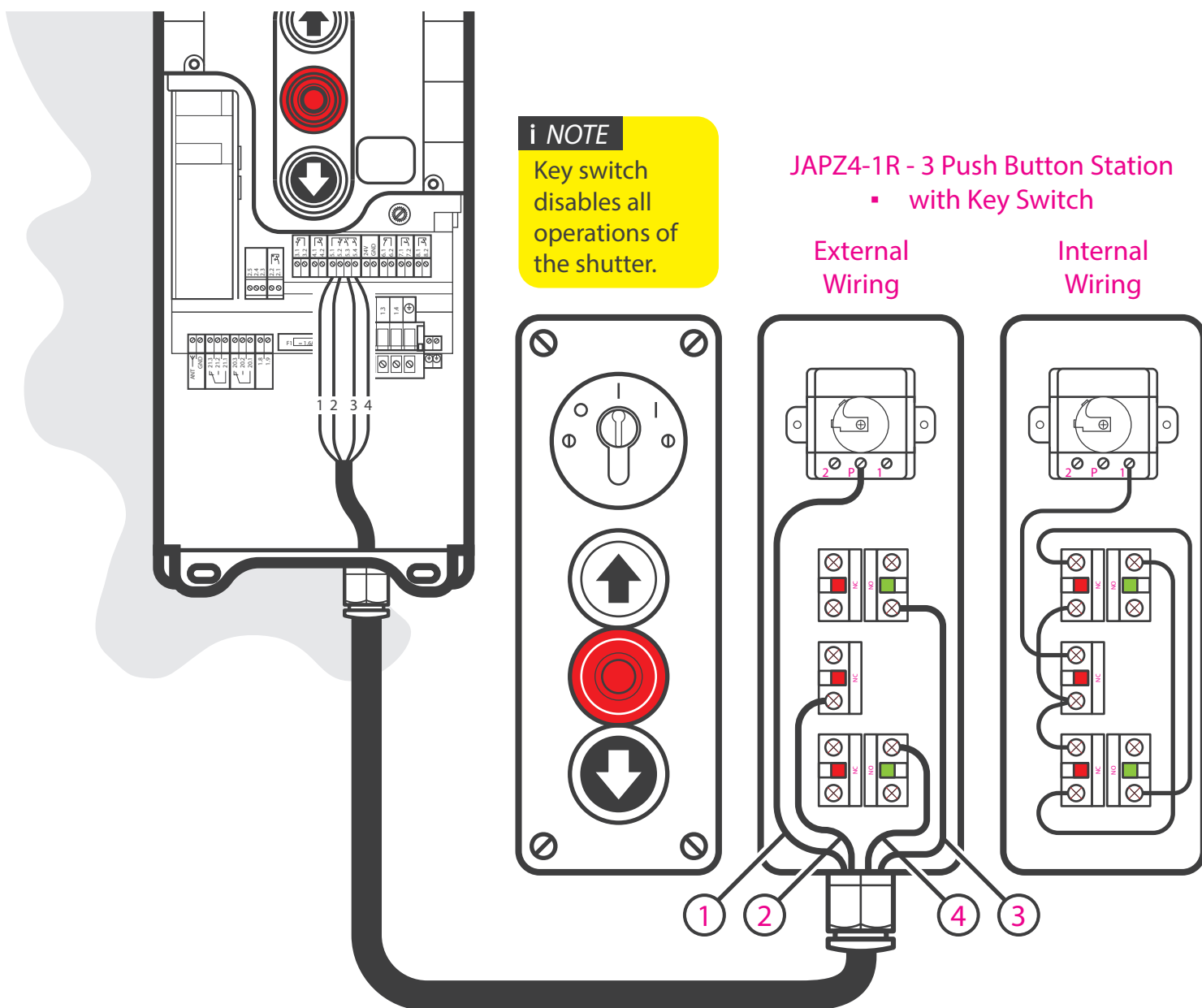

⚠ WARNING

Danger due to unattended door movement!

The safety devices are deactivated in operating mode hold-to-run. People or objects in the movement path are not detected.

- Install and operate the control device with a clear view of the door.

The Push Button Station must be in clear view of the door, and should be operated by trained users ONLY, or a photocell and safety edge must be fitted to detect persons or obstacles standing on the floor to one side of the door.

Latching Stop Push Buttons are recommended for all doors that can be started remotely or automatically by vehicles approaching the door.

- See page 15 for instructions on fitting a Latching Stop Push Button.

Connecting a JAPZ4 - 1R

Alternative Wiring Arrangement

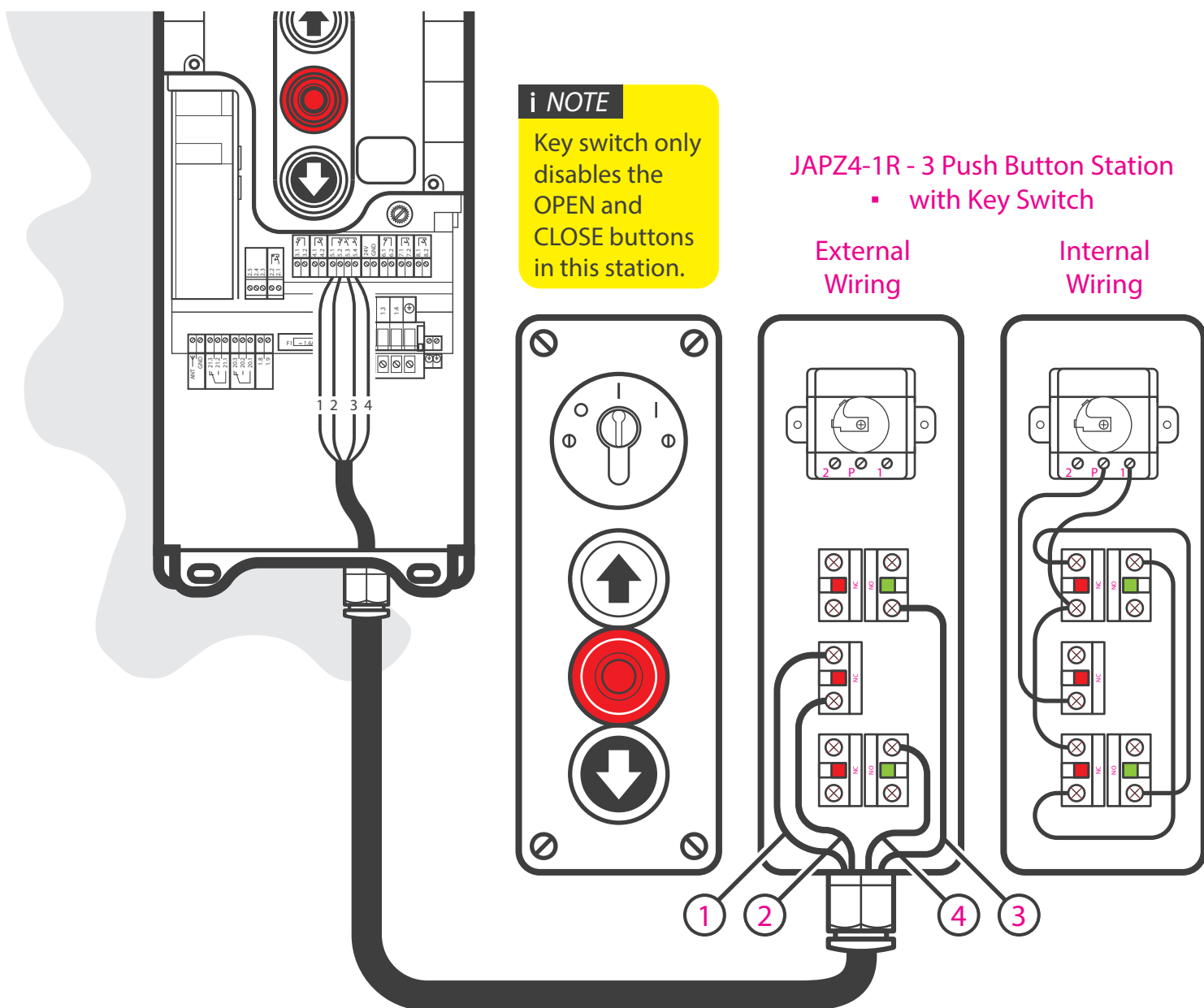

⚠ WARNING

Danger due to unattended door movement!

The safety devices are deactivated in operating mode hold-to-run. People or objects in the movement path are not detected.

- Install and operate the control device with a clear view of the door.

The Push Button Station must be in clear view of the door, and should be operated by trained users ONLY, or a photocell and safety edge must be fitted to detect persons or obstacles standing on the floor to one side of the door.

Latching Stop Push Buttons are recommended for all doors that can be started remotely or automatically by vehicles approaching the door.

- See page 15 for instructions on fitting a Latching Stop Push Button.

2No. PES/30T

▪ Through-Beam Photocells

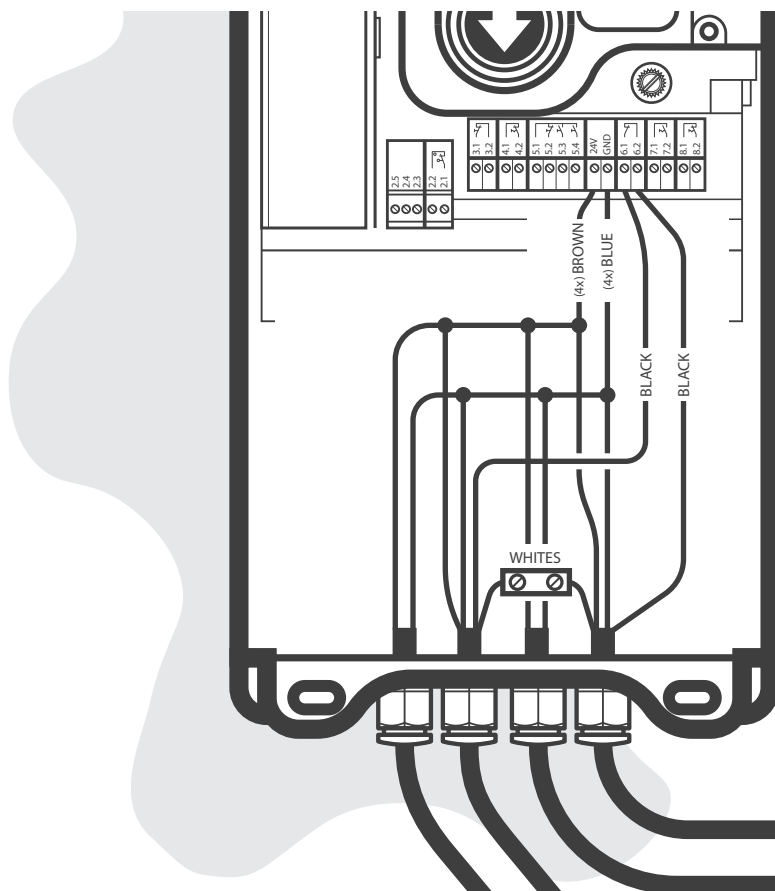

i NOTE

Only fitting photocells to the door does not constitute a safety device for automatic operation.

- For a safety device on the leading edge then please view the guidelines on page 26.

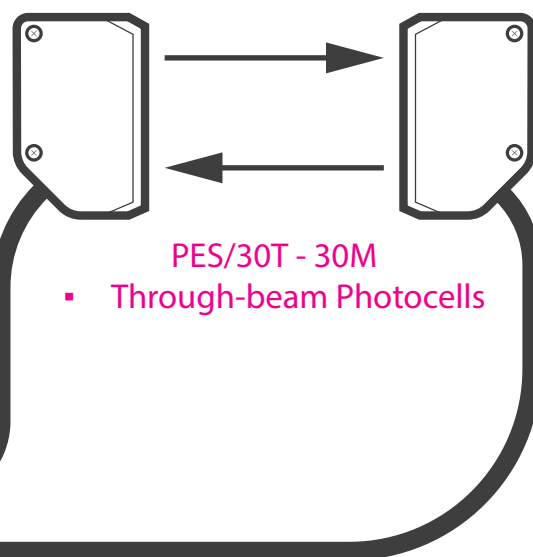

⚠ CAUTION

Injuries caused by uncontrolled movement or damage to property.

The controller does not detect defects on photocells that use a de-energised normally closed contact (N/C). Failure of the photocell may result in injuries due to crushing, shearing or impact.

- Use photocells with a normally open (N/O) contact that is held closed when energised.
- Carry out periodic checks in-line with BS EN 12453.

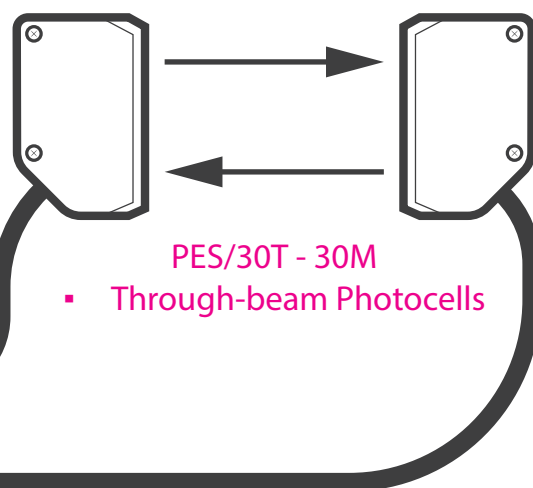

i NOTE

- Link between 6.1 and 6.2 needs to be removed.
- Grey wire on the photocells not used. Isolate and make safe.

Brown	24 VDC
Blue	
White	Relay COM
Grey	Relay N/C Held OPEN
Black	Relay N/O Held CLOSED

1No. PES/30T

▪ Through-Beam Photocells

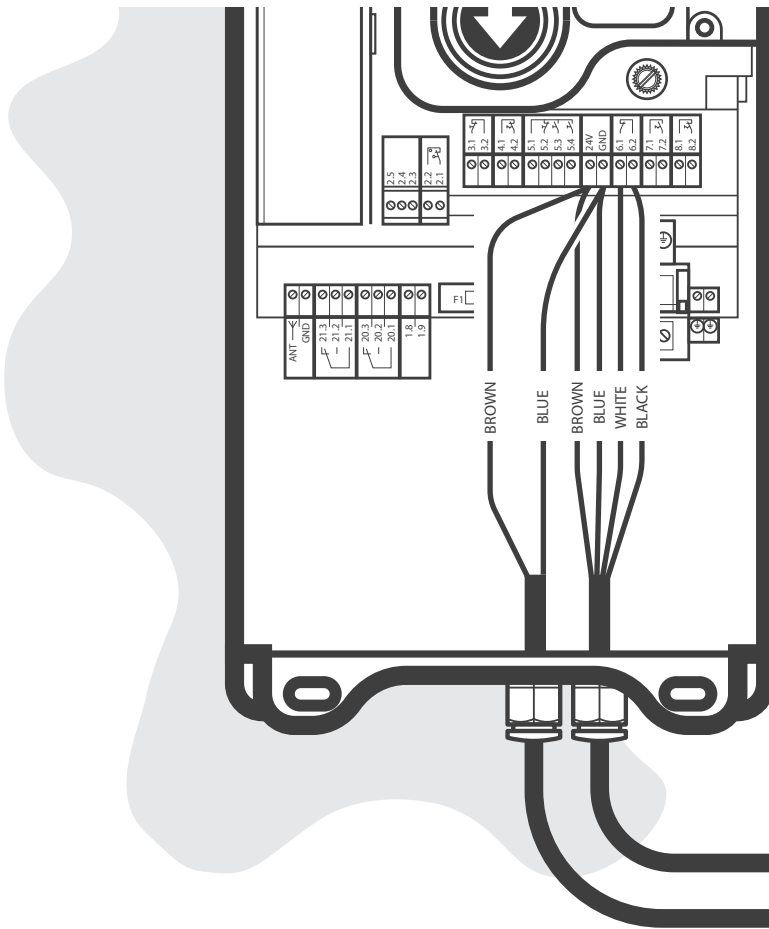

i NOTE

Only fitting photocells to the door does not constitute a safety device for automatic operation.

- For a safety device on the leading edge then please view the guidelines on page 26.

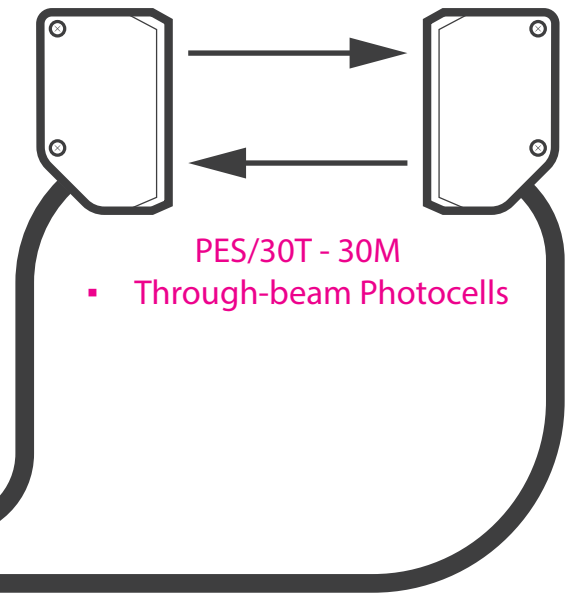

i NOTE

- Link between 6.1 and 6.2 needs to be removed.
- Grey wire on the photocells not used. Isolate and make safe.

⚠ CAUTION

Injuries caused by uncontrolled movement or damage to property.

The controller does not detect defects on photocells that use a de-energised normally closed contact (N/C). Failure of the photocell may result in injuries due to crushing, shearing or impact.

- Use photocells with a normally open (N/O) contact that is held closed when energised.
- Carry out periodic checks in-line with BS EN 12453.

Brown	24 VDC
Blue	
White	Relay COM
Grey	Relay N/C Held OPEN
Black	Relay N/O Held CLOSED

2No. PES/9R

▪ Reflective Photocells

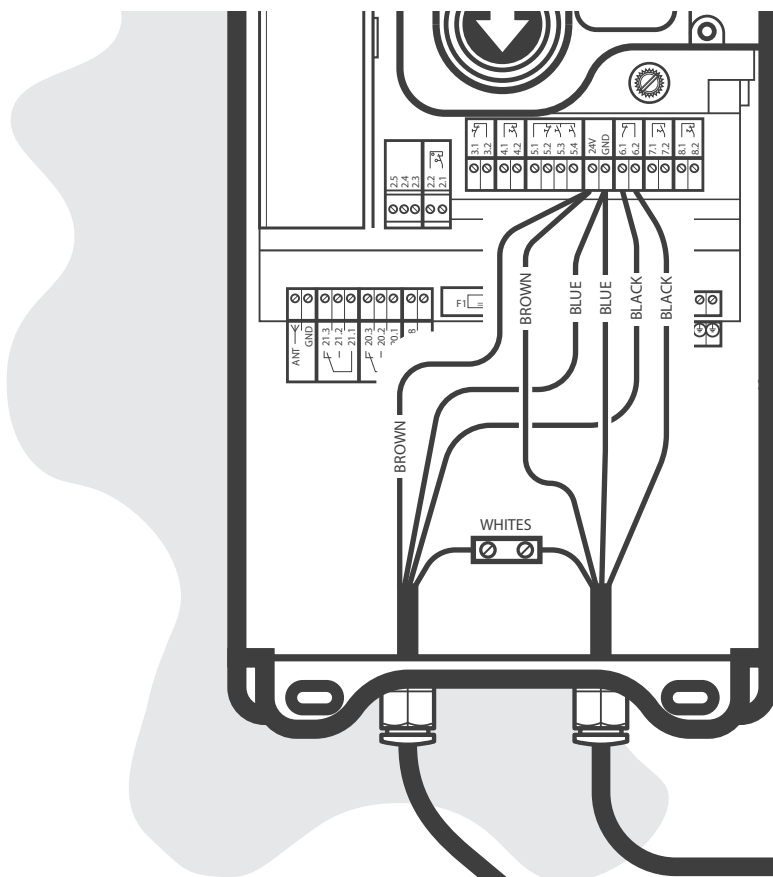

i NOTE

Only fitting photocells to the door does not constitute a safety device for automatic operation.

- For a safety device on the leading edge then please view the guidelines on page 26.

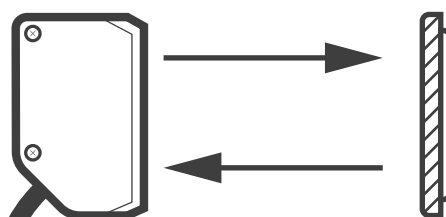

PES/9R - 9m Range
▪ Polarised Reflective Photocells

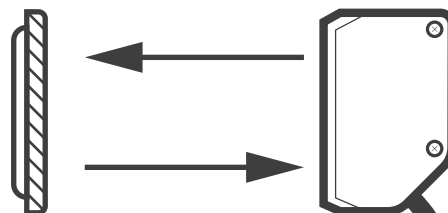

PES/9R - 9m Range
▪ Polarised Reflective Photocells

⚠ CAUTION

Injuries caused by uncontrolled movement or damage to property.

The controller does not detect defects on photocells that use a de-energised normally closed contact (N/C). Failure of the photocell may result in injuries due to crushing, shearing or impact.

- Use photocells with a normally open (N/O) contact that is held closed when energised.
- Carry out periodic checks in-line with BS EN 12453.

i NOTE

- Link between 6.1 and 6.2 needs to be removed.
- Grey wire on the photocells not used. Isolate and make safe.

Brown	24 VDC
Blue	
White	Relay COM
Grey	Relay N/C Held OPEN
Black	Relay N/O Held CLOSED

1No. PES/9R

▪ Reflective Photocell

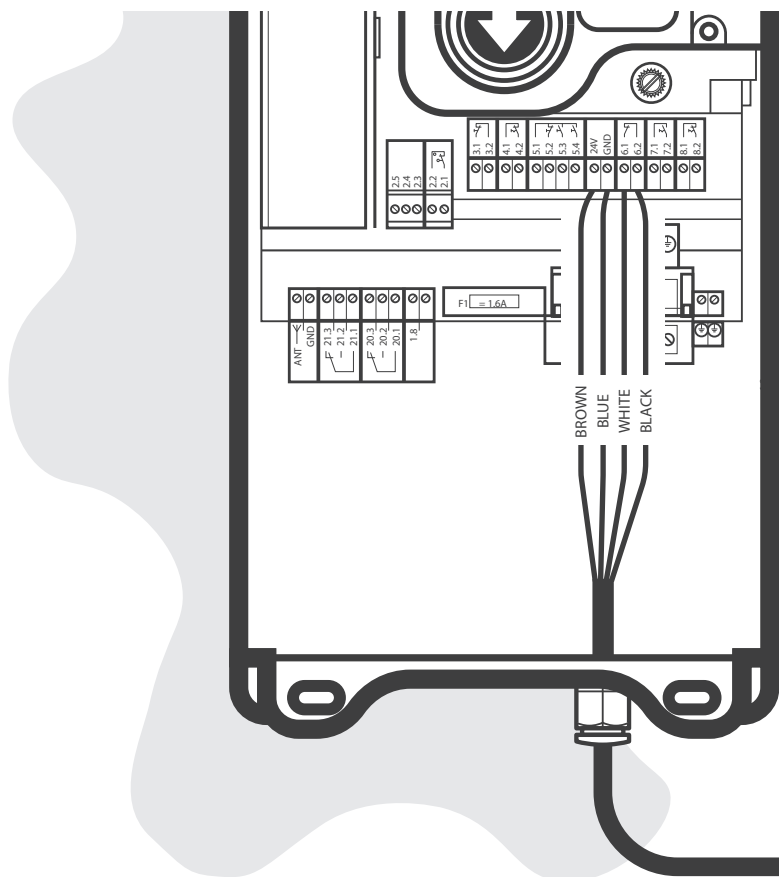

i NOTE
 Only fitting photocells to the door does not constitute a safety device for automatic operation.
 ▪ For a safety device on the leading edge then please view the guidelines on page 26.

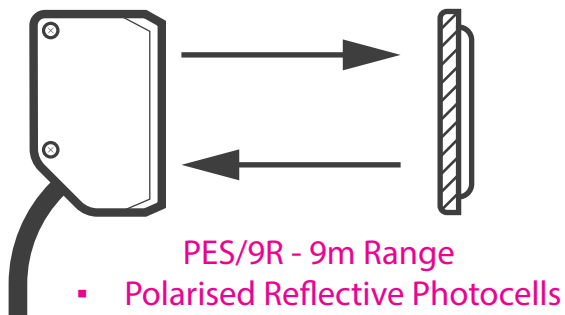

i NOTE
 ▪ Link between 6.1 and 6.2 needs to be removed.
 ▪ Grey wire on the photocells not used. Isolate and make safe.

⚠ CAUTION
Injuries caused by uncontrolled movement or damage to property.
 The controller does not detect defects on photocells that use a de-energised normally closed contact (N/C) . Failure of the photocell may result in injuries due to crushing, shearing or impact.
 ▪ Use photocells with a normally open (N/O) contact that is held closed when energised.
 ▪ Carry out periodic checks in-line with BS EN 12453.

Brown	24 VDC
Blue	
White	Relay COM
Grey	Relay N/C Held OPEN
Black	Relay N/O Held CLOSED

2no. PES/4.5TOF/POT

▪ Time-of-Flight Photocells

i NOTE

Only fitting photocells to the door does not constitute a safety device for automatic operation.

- For a safety device on the leading edge then please view the guidelines on page 26.

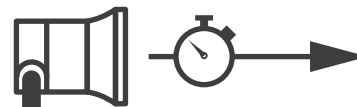
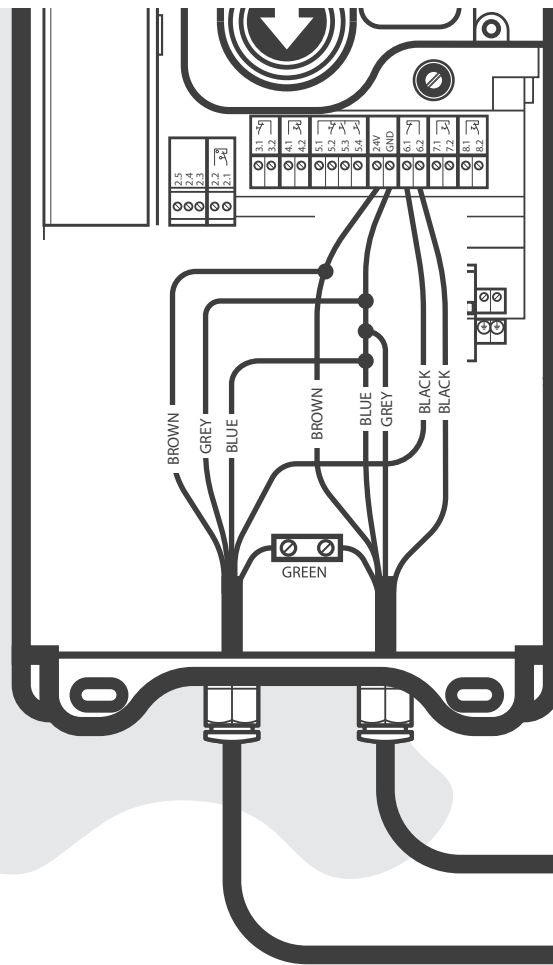

PPES/4.5TOF/POT
▪ TOF Photocell



PPES/4.5TOF/POT
▪ TOF Photocell

⚠ CAUTION

Injuries caused by uncontrolled movement or damage to property.

The controller does not detect defects on photocells that use a de-energised normally closed contact (N/C). Failure of the photocell may result in injuries due to crushing, shearing or impact.

- Use photocells with a normally open (N/O) contact that is held closed when energised.
- Carry out periodic checks in-line with BS EN 12453.

Brown	24 VDC
Blue	24 VDC
Green	Relay COM
Black	Relay N/C
Grey	Logic Selector

i NOTE

- Link between 6.1 and 6.2 needs to be removed.
- White wire on the TOF photocells not used. Isolate and make safe.

1No. PES/4.5TOF/POT

▪ Time-of-Flight Photocell

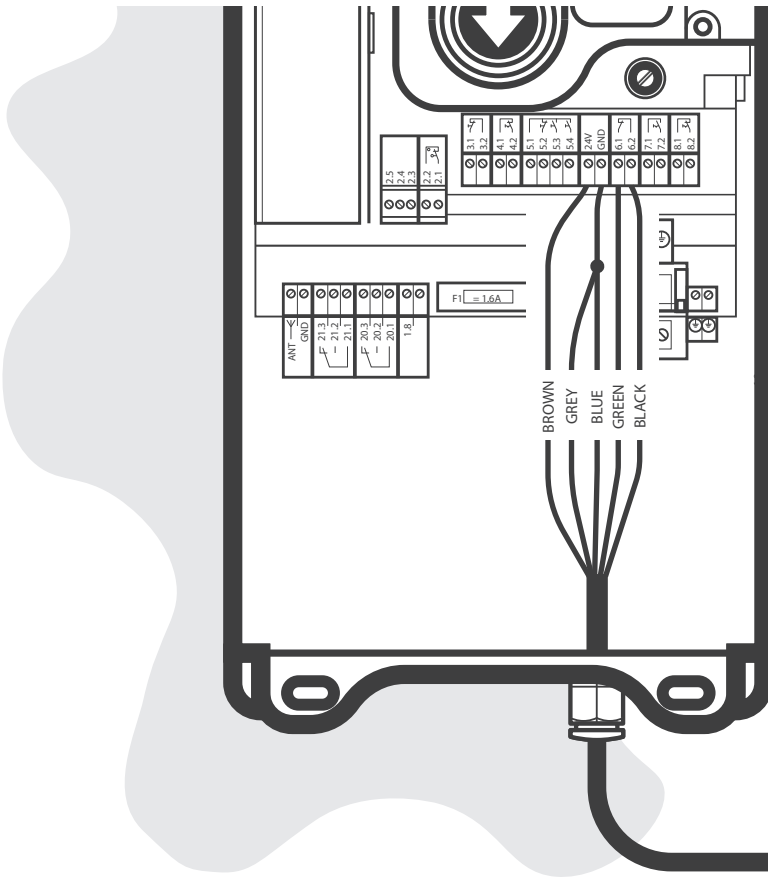

i NOTE

Only fitting photocells to the door does not constitute a safety device for automatic operation.

- For a safety device on the leading edge then please view the guidelines on page 26.

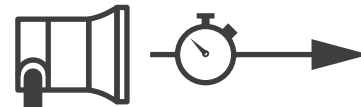

PES/4.5TOF/POT
▪ TOF Photocell

i NOTE

- Link between 6.1 and 6.2 needs to be removed.
- White wire on the TOF photocells not used. Isolate and make safe.

⚠ CAUTION

Injuries caused by uncontrolled movement or damage to property.

The controller does not detect defects on photocells that use a de-energised normally closed contact (N/C). Failure of the photocell may result in injuries due to crushing, shearing or impact.

- Use photocells with a normally open (N/O) contact that is held closed when energised.
- Carry out periodic checks in-line with BS EN 12453.

Brown	24 VDC
Blue	
Green	Relay COM
Black	Relay N/C
Grey	Logic Selector

▪ **Minimum Levels of Safeguarding**

- **Type 1:** A Limited group of persons are trained to operate the door and the door is out of a public area.
- **Type 2:** A Limited group of persons are trained to operate the door and the door is in a public area.
- **Type 3:** Any person is free to operate the door and the door is in contact with the general public.

Type of Door Activation	Types of User / Location		
	Trained Users (public not likely to be present) Type 1	Trained Users (public likely to be present) Type 2	Untrained Users Type 3
Hold-to-run control mode of operation	A	B	Not Possible
Impulse Activation in sight of the door	C or E	C or E	C & D or E
Impulse Activation out of sight of the door	C or E	C & D or E	C & D or E
Automatic Control	C & D or E	C & D or E	C & D or E

- In sight of the door is from a position that allows full, direct and permanent real-time view of the door at activation and during the entire movement.
- **A:** Hold-to-run push button control.
- **B:** Hold-to-run control with key switch or similar.
- **C:** Limitation of forces. (Limited by the speed and weight of the shutter or by detection and stop and re-open control).
- **D:** A means for detection of presence of a person or obstacle standing on the floor at one side of the door.
1 or 2 Photocells at low level to give stop and return safety on curtain closing so as to be in compliance with BS EN 12453 5.2.1.8.
- **E:** A means for detection of presence which is designed and installed in a way that in no circumstances can a person be touched by the moving door leaf.

KSR4P

Wired Safety Edge Connections

Before setting the limits on the door ensure parameter **0.3** is set to the default setting of **.1**.

- This is only on TS 971 controllers with software version 2.9 and above.

Shoot Bolt, Pass Door or Slack Rope Switch (X2, X3 and X4).

- Remove Link if connecting.

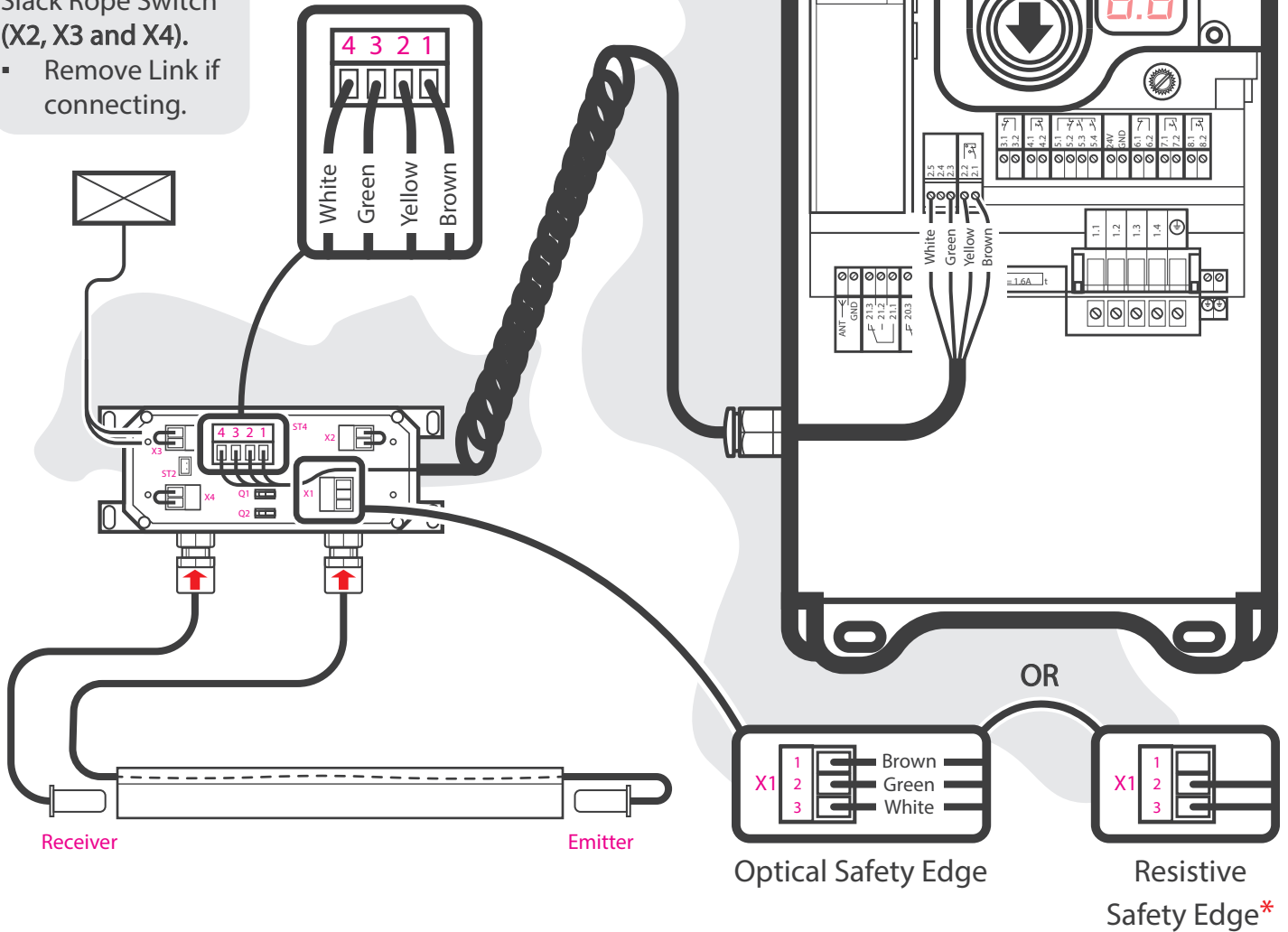

i NOTE

- Connect 5k2 resistor in series with older types of slack rope switches if it is required.
- New slack rope switches and pass door contacts **do not** need the resistor.

*When connecting a resistive safety edge, connect the white core from the spiral cable into terminal 2.4 on the TS controller.

If panel shows code **F 1.B** then check positioning of the resistor and need for it.

Wired Safety Edge Connections

Set switches Q1 and Q2

- You will find the switches **Q1** and **Q2** on the board. **Q1** and **Q2** are used to switch the cross-fault monitoring of the slack-rope and pass-door switches.

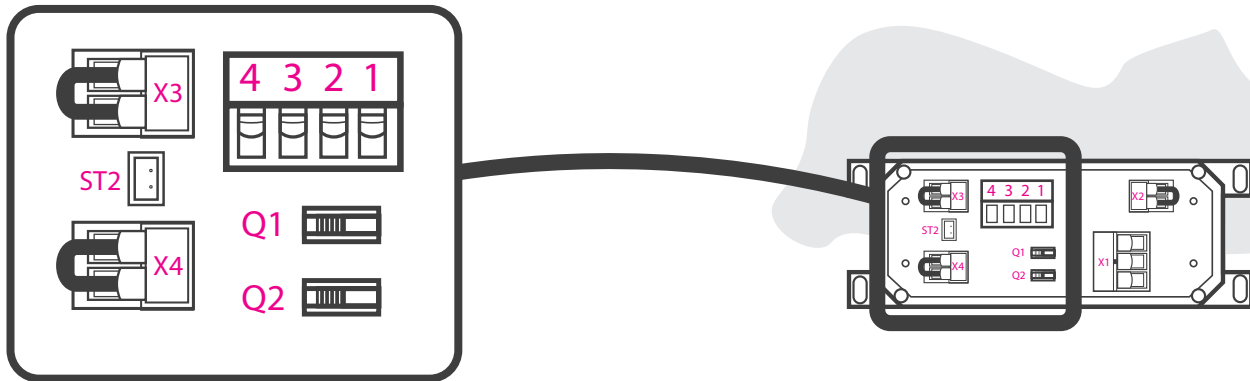

Select the required setting from the following table.

Slack-Rope Switch	Pass-Door Switch	Q1	Q2
2 Switches with cross-fault monitoring	▪ One switch with cross-fault monitoring	ON	ON
	▪ One switch without cross-fault monitoring	ON	OFF
	▪ Without switch	ON	OFF
2 Switches without cross-fault monitoring	▪ One switch with cross-fault monitoring	OFF	ON
	▪ One switch without cross-fault monitoring	OFF	OFF
	▪ Without switch	OFF	OFF
Without switch	▪ One switch with cross-fault monitoring	OFF	ON
	▪ One switch without cross-fault monitoring	OFF	OFF
	▪ Without switch	OFF	OFF

Wired Safety Edge Connections

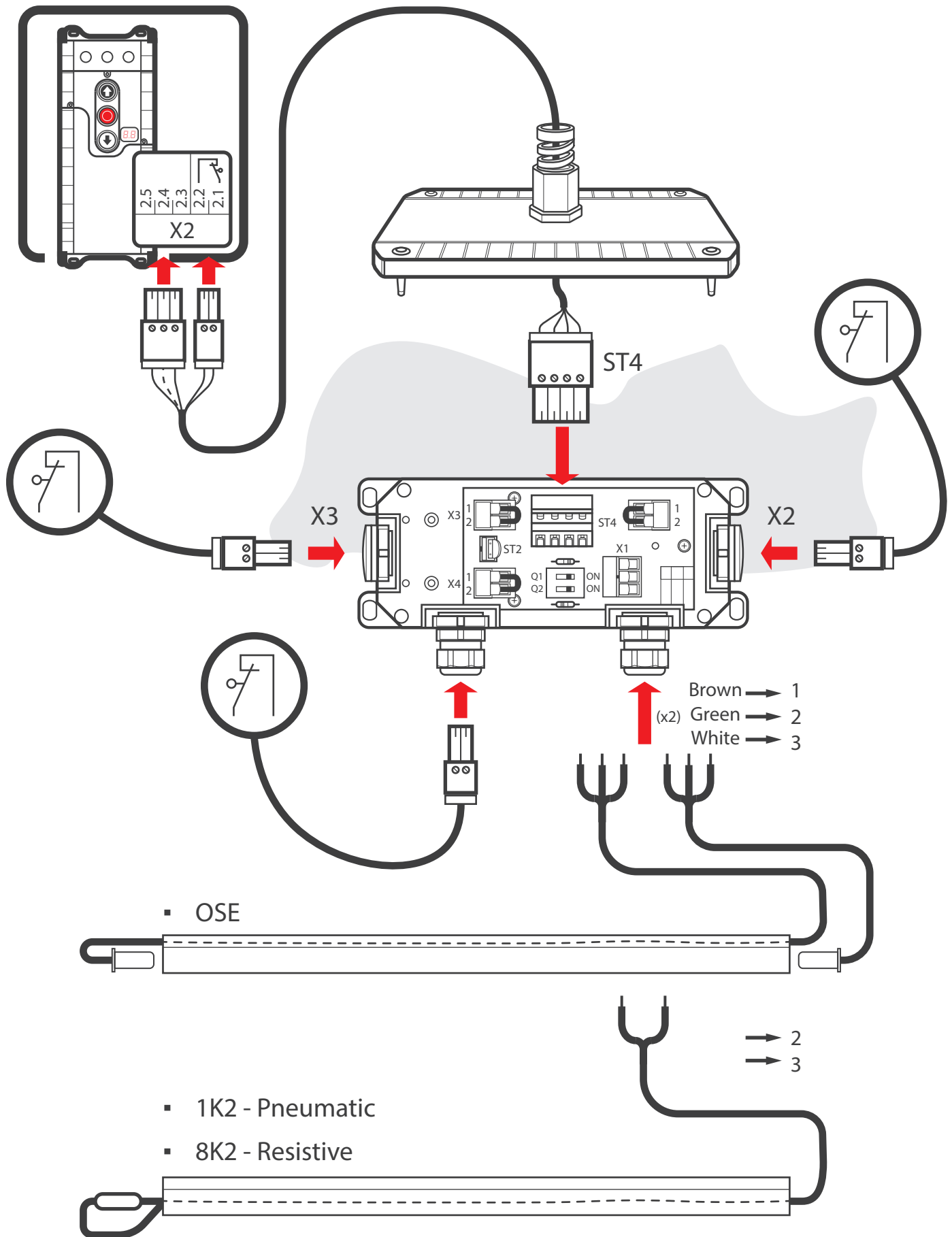

Wireless Safety Edge

Before setting the limits on the door, please ensure parameter **0.3** is set to **.1**.
 This setting is only available on a TS 971 control panel with software version 2.9 and above.

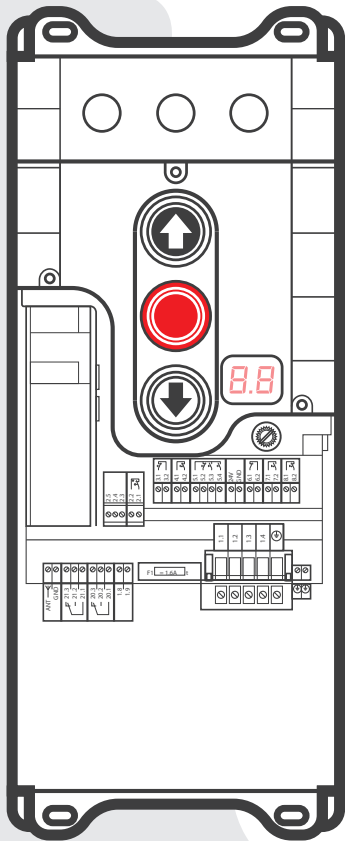

Shoot Bolt,
 Pass Door or
 Slack Rope Switch
 (X1 or X2).
 Remove Link if
 connecting.

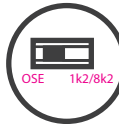

DIP Switch Settings
 OSE = Optical Eyes.
 1k2 / 8k2 = Pneumatic or Resistive Edges.

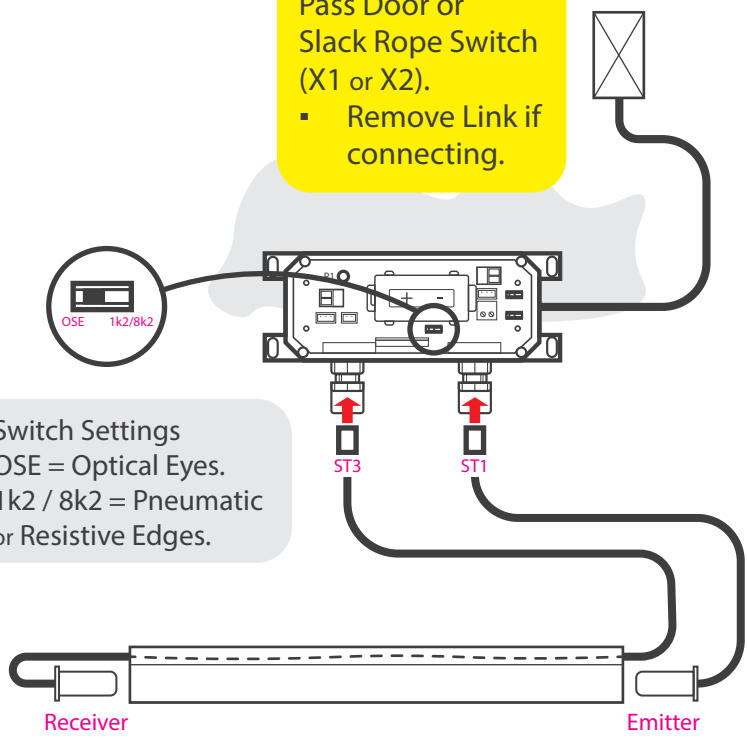

10m MAX

Avoid obstructions e.g. Steel or Reinforced Concrete

Obstructions will reduce operational range or completely block signal

Systems in the same area must be programmed to different channels

Example Channel: .2

Example Channel: 1.4

1. Initial setup of the control panel.
2. Pressing the '0.0' button for 3 seconds.
3. Pressing the '2.0' button for 1 second, with a '2 - 4.0' range indicator.
4. Pressing the '1.1' button for 30 seconds.
5. Pressing the 'P1' button on the receiver unit.

Channel Range Available

Wireless Safety Edge (DIP Switch Settings)

i NOTE

Terminals X2 (2.1 - 2.5) are disabled when a wireless safety edge system is used with a TS 971.

- If using a light curtain as a primary source of safety, the wireless safety edge module can still be used as a means of wirelessly connecting slack rope switches and pass-door contacts to the TS control panel.

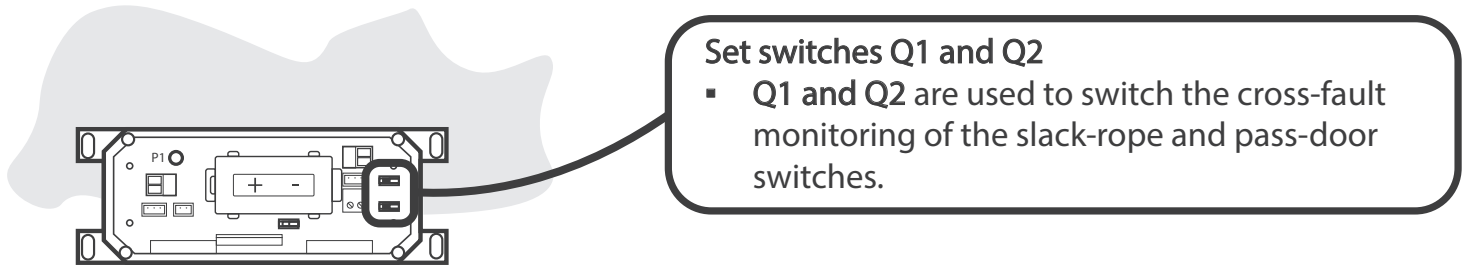

Select the required setting from the following table.

Slack-Rope Switch	Pass-Door Switch	Q1	Q2
2 Switches with cross-fault monitoring	▪ One switch with cross-fault monitoring	ON	ON
	▪ One switch without cross-fault monitoring	ON	OFF
	▪ Without switch	ON	OFF
2 Switches without cross-fault monitoring	▪ One switch with cross-fault monitoring	OFF	ON
	▪ One switch without cross-fault monitoring	OFF	OFF
	▪ Without switch	OFF	OFF
Without switch	▪ One switch with cross-fault monitoring	OFF	ON
	▪ One switch without cross-fault monitoring	OFF	OFF
	▪ Without switch	OFF	OFF

Set Switch Q3

- Use switch Q3 to select the type of safety edge.

Safety Edge Type	Switch Position
▪ Optical	Left
▪ Pneumatic	Right (1K2 resistor)
▪ Electrical / Resistive	Right (8K2 resistor)

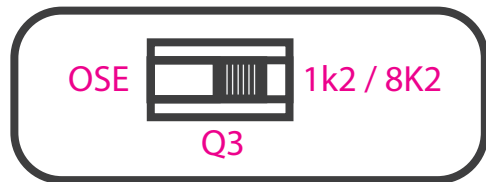

“Cross- fault monitoring” is the monitoring of the safety edge and the X1 and X2 terminals when they are used for slack rope switches and pass door contacts.

GF304528 RAYTECTOR



▪ High Level Entrapment Protection Barrier

i NOTE

Read the Raytector instructions for essential installation and testing procedures.

i NOTE

When using an FI drive unit, do not connect into X3 (3.1 and 3.2) - please use terminals X5 (5.1 and 5.2).

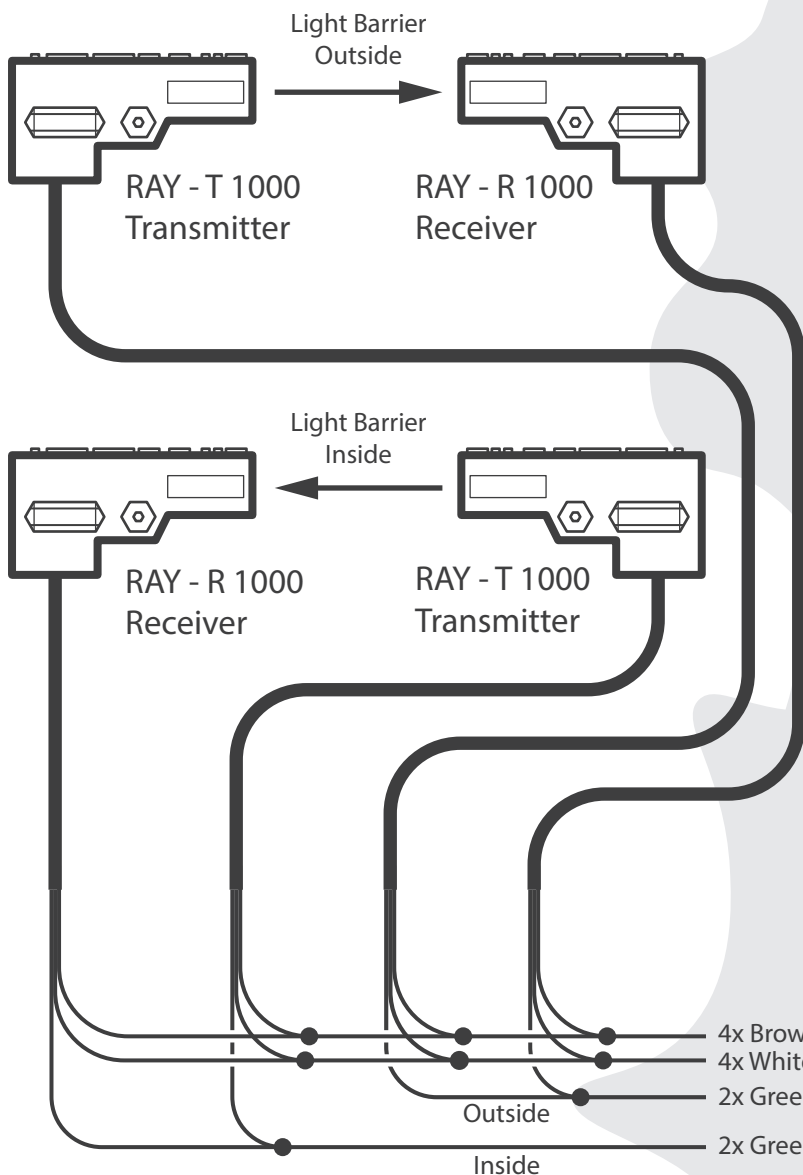

i NOTE

Link between terminals 5 and 6 on the OSE box to be removed when 2no. Raytector systems installed as shown.

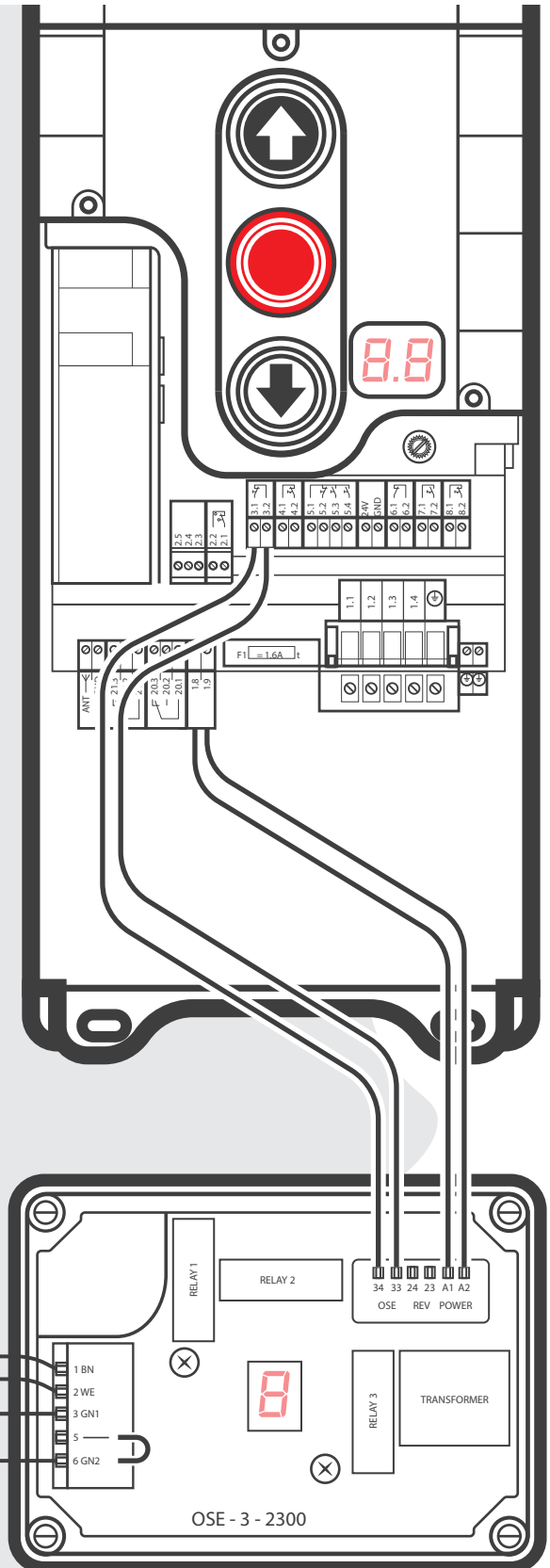

▪ Light Curtain

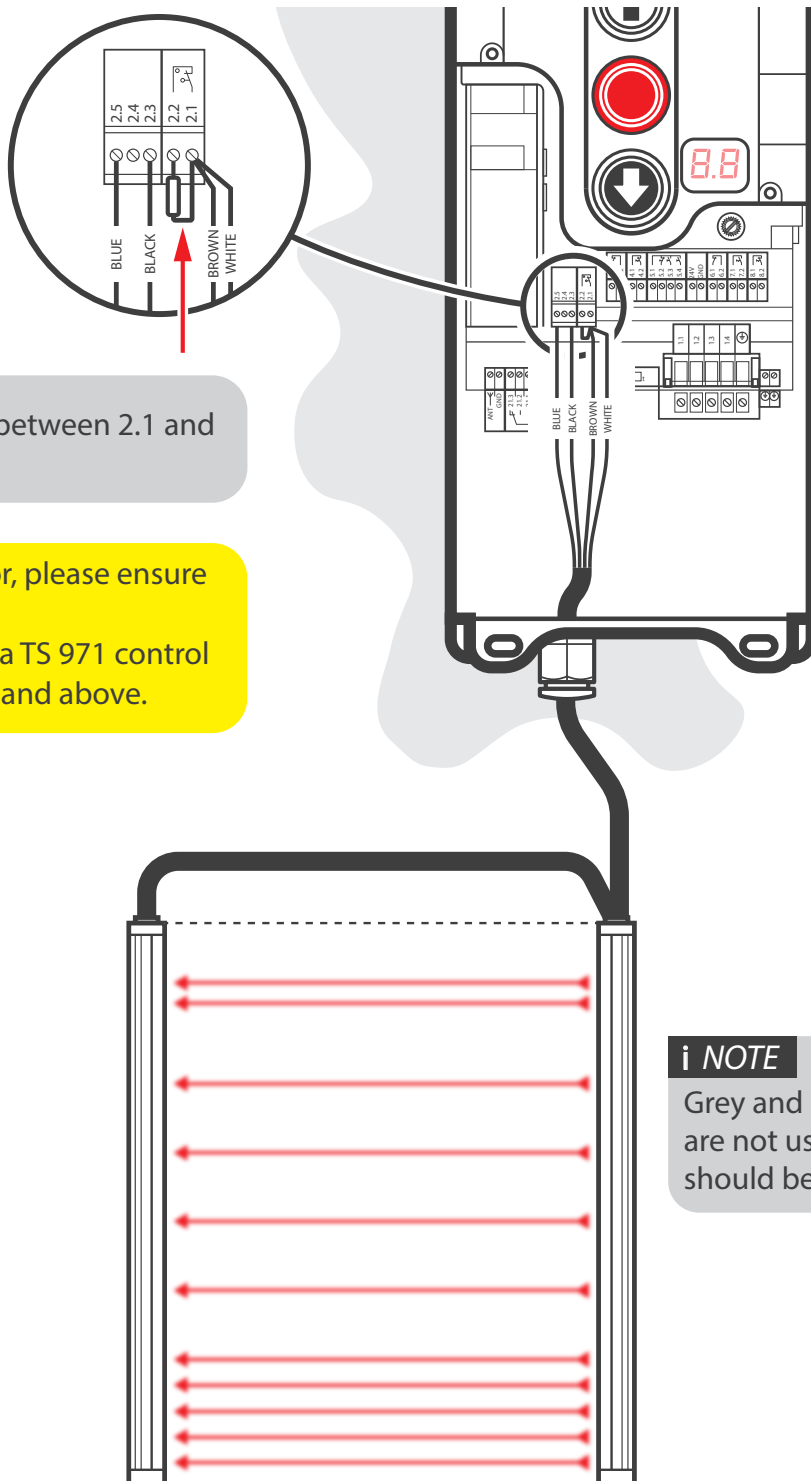

Leave the factory fitted 5k resistor between 2.1 and 2.2 in place.

Before setting the limits on the door, please ensure parameter $\bar{0.3}$ is set to $.2$.

- This setting is only available on a TS 971 control panel with software version 2.9 and above.

i NOTE

Grey and Green cables are not used and should be made safe.

i NOTE

A light curtain can be used instead of a safety edge providing that it is fitted directly under the leading edge of the door and is certified as a Type 'E' device according to BS EN 12453.

Light Curtains

Leave the factory fitted 5k2 resistor between 2.1 and 2.2 in place, and fit a 1k2 resistor into terminal 2.4 as per the diagram shown.

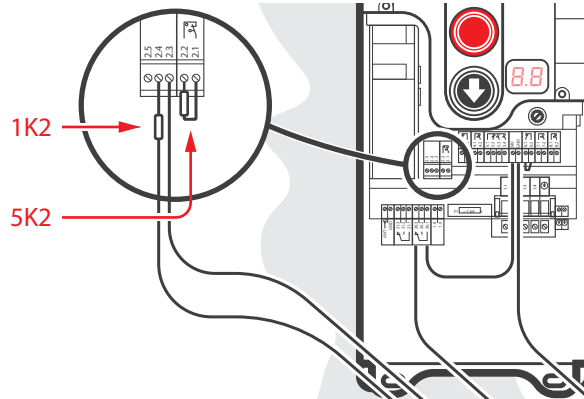

Before setting the limits on the door, ensure parameter **0.3** is set to **.1** when using light curtains as a safety device.

- This setting is only available on a TS 971 control panel with software version 2.9 and above.

GF10010/2B
Opto-electronic Safety Control Board
24V AC/DC

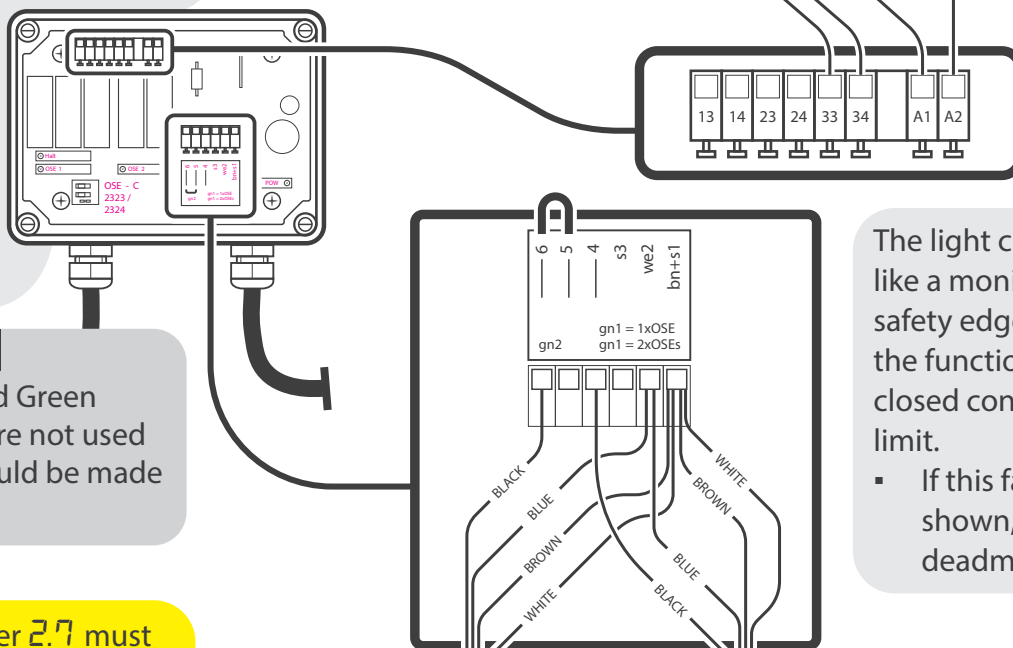

i NOTE

Grey and Green cables are not used and should be made safe.

The light curtains are connected like a monitored pneumatic safety edge and the TS 971 tests the function of the normally closed contact at the bottom limit.

- If this fails an **F 2.8** fault is shown, reverting the door to deadman operation.

Parameter **2.7** must be set to **.8**.

- When the door is closed the light curtains are switched OFF. The light curtains are only active when the door is NOT closed.

Light Curtain 2

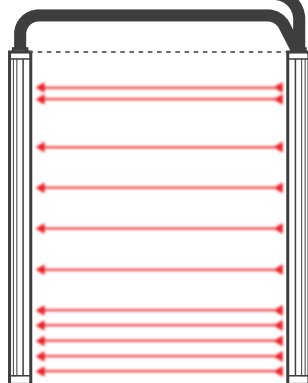

Light Curtain 1

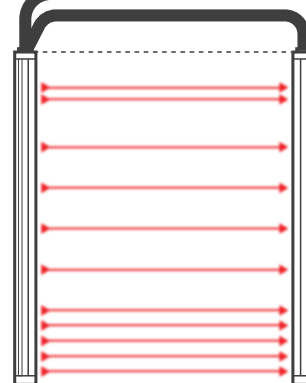

i NOTE

When installing 2 light curtains, remove link between terminals 5 and 6 in the GF10010/2B relay box.

i NOTE

When using two sets of light curtains, one set must be installed on either side of the door, with a max. distance of 200mm between the centre of the curtains. To prevent interferences between two sets of light curtains they must be mounted with the light beam direction being in the opposite direction.

1 No. KGF/RAY-LG25xx/OSE

▪ Light Curtains and KSR6 Wireless Safety Edge Box

In this configuration, the wireless safety edge module can only be used for the use of slack rope switches and pass door contacts.

- The primary source of leading edge safety is provided by the installed light curtain.

Before setting the limits on the door, ensure parameter **0.3** is set to **.3** when using a KSR6 for slack rope switches.

- This setting is only available on a TS 971 control panel with software version 2.9 and above.

i NOTE

Once limits are set the door controller will show **F 1.2** until the WSD is programmed.

Shoot Bolt, Pass Door or Slack Rope Switch (X1 or X2).

- Remove Link if connecting.

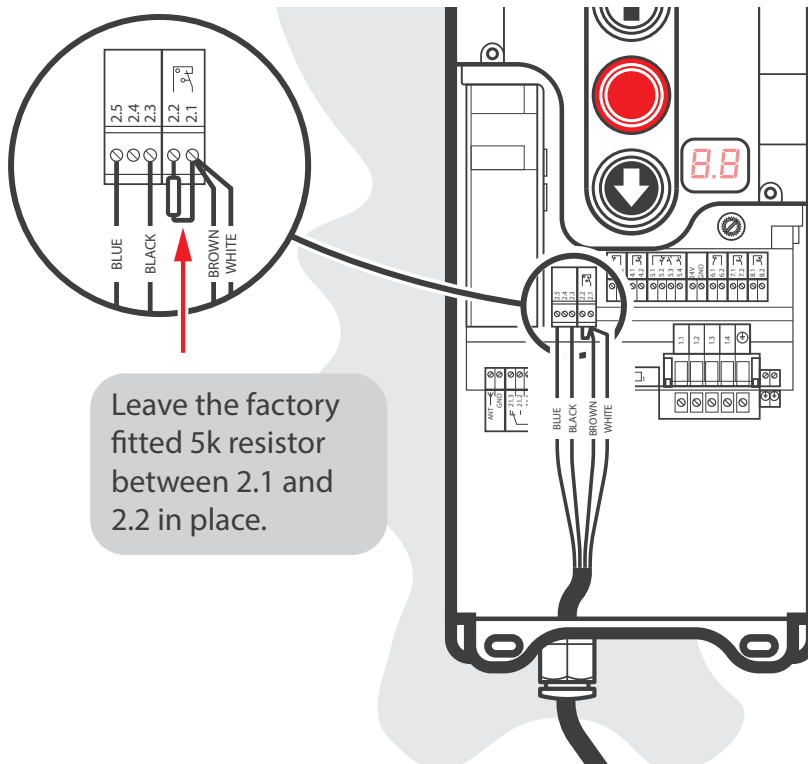
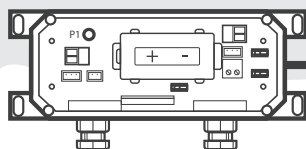

Leave the factory fitted 5k resistor between 2.1 and 2.2 in place.

i NOTE

Grey and Green cables are not used and should be made safe.

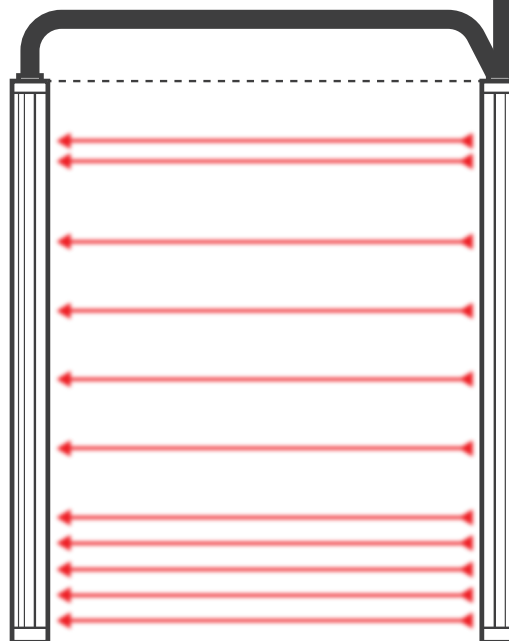

i NOTE

A light curtain can be used instead of a safety edge providing that it is fitted directly under the leading edge of the door and is certified as a Type 'E' device according to BS EN 12453.

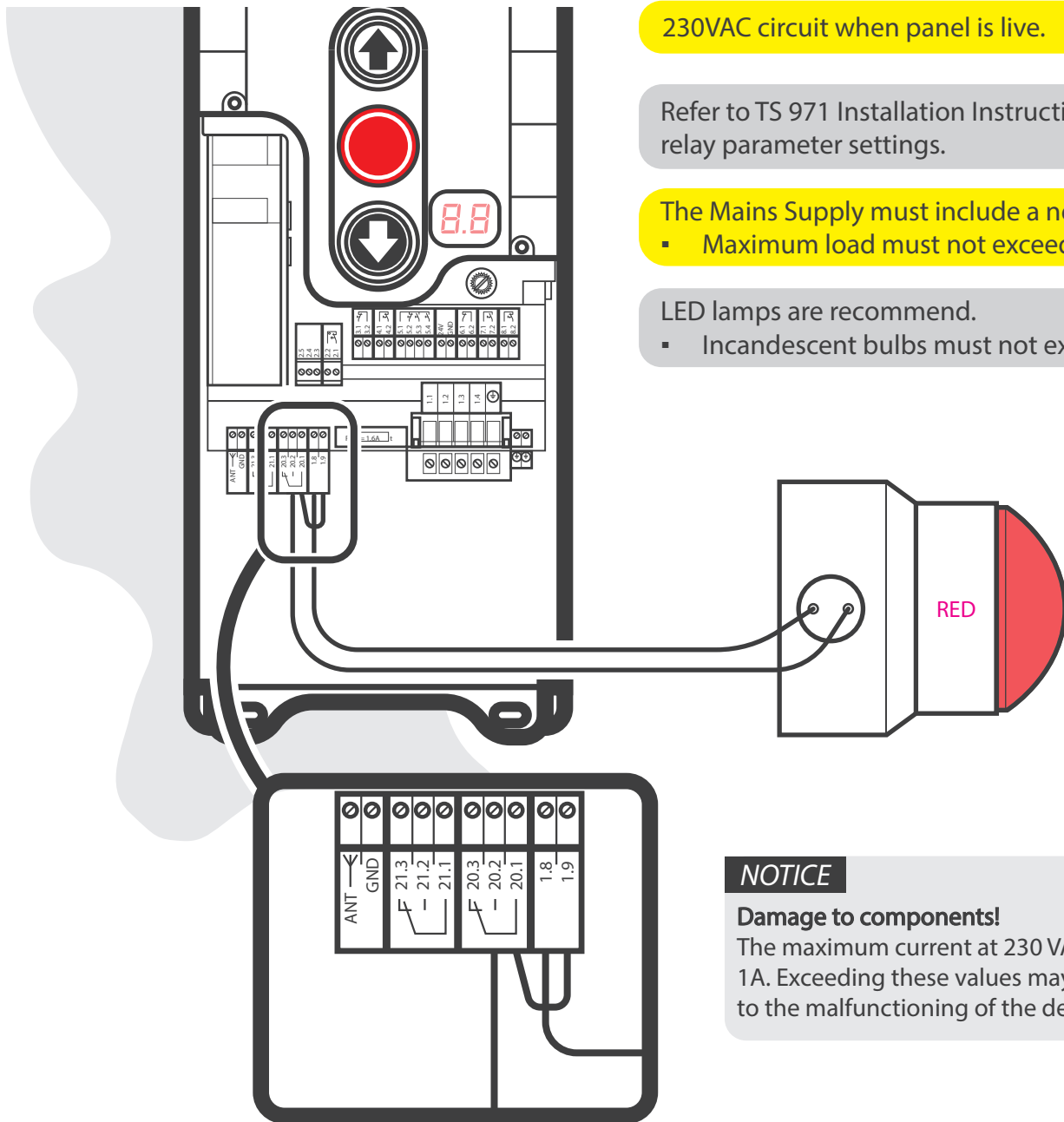

230VAC circuit when panel is live.

Refer to TS 971 Installation Instructions for relay parameter settings.

The Mains Supply must include a neutral.

- Maximum load must not exceed 1A.

LED lamps are recommend.

- Incandescent bulbs must not exceed 40W.

NOTICE

Damage to components!

The maximum current at 230 VAC is 1A. Exceeding these values may lead to the malfunctioning of the devices.

⚠ WARNING

- **Danger to life from electric shock!**
- Improper wiring may result in severe or fatal injury from electrical shock.
- Allow only competent or skilled persons to carry out the work.
- Follow safe isolation procedures on the power source.
- Observe valid regulations and standards.
- Use suitable tools.
- Ensure all equipment is selected and installed suitably for the environment and intended use.

(230VAC) Red/Green Traffic Indicator



▪ GE301955

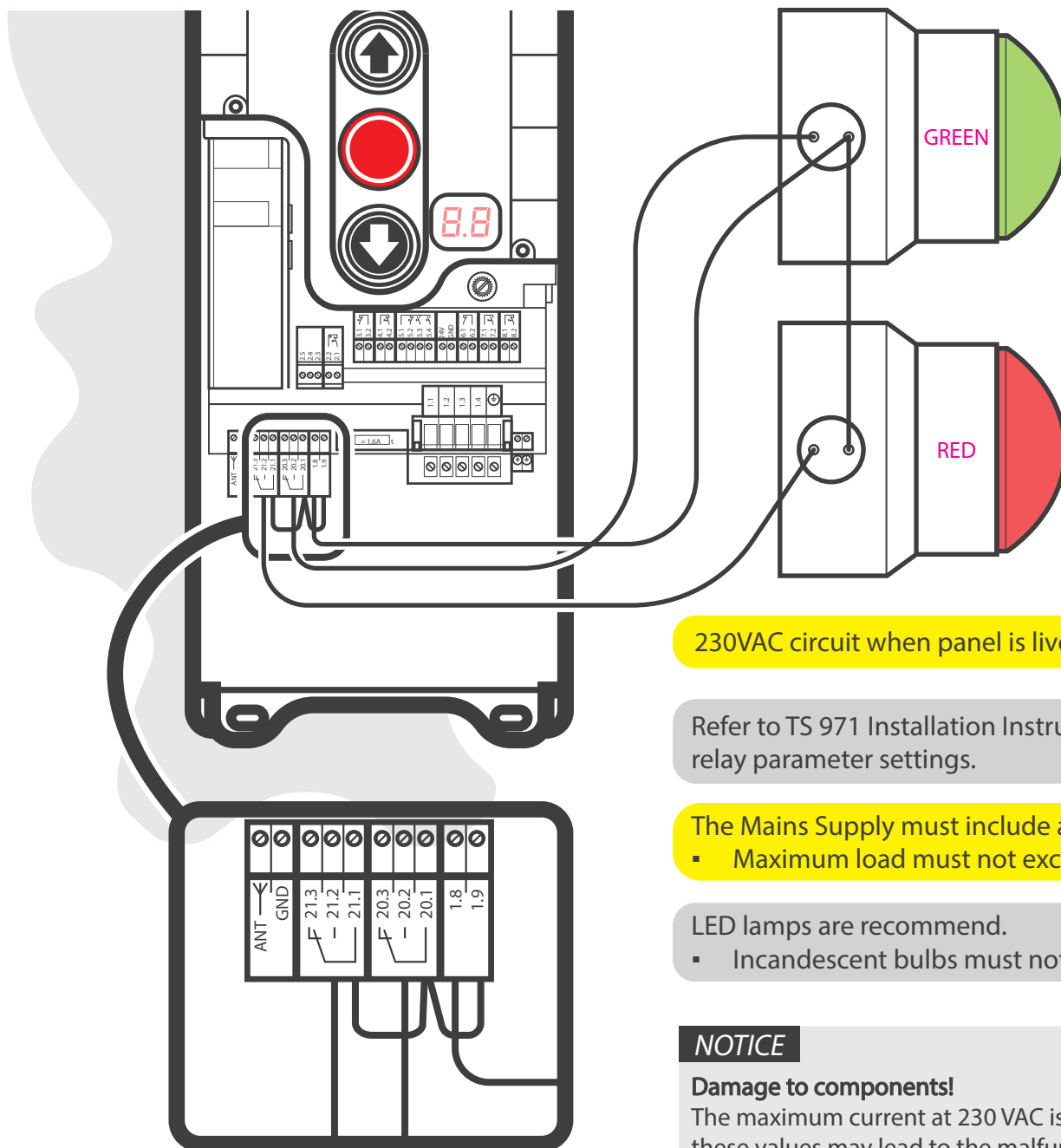

230VAC circuit when panel is live.

Refer to TS 971 Installation Instructions for relay parameter settings.

The Mains Supply must include a neutral.
▪ Maximum load must not exceed 1A.

LED lamps are recommend.
▪ Incandescent bulbs must not exceed 40W.

NOTICE

Damage to components!

The maximum current at 230 VAC is 1A. Exceeding these values may lead to the malfunctioning of the devices.

⚠ WARNING

- **Danger to life from electric shock!**
- Improper wiring may result in severe or fatal injury from electrical shock.
- Allow only competent or skilled persons to carry out the work.
- Follow safe isolation procedures on the power source.
- Observe valid regulations and standards.
- Use suitable tools.
- Ensure all equipment is selected and installed suitably for the environment and intended use.

▪ Red/Green Traffic Indicator (24VDC)

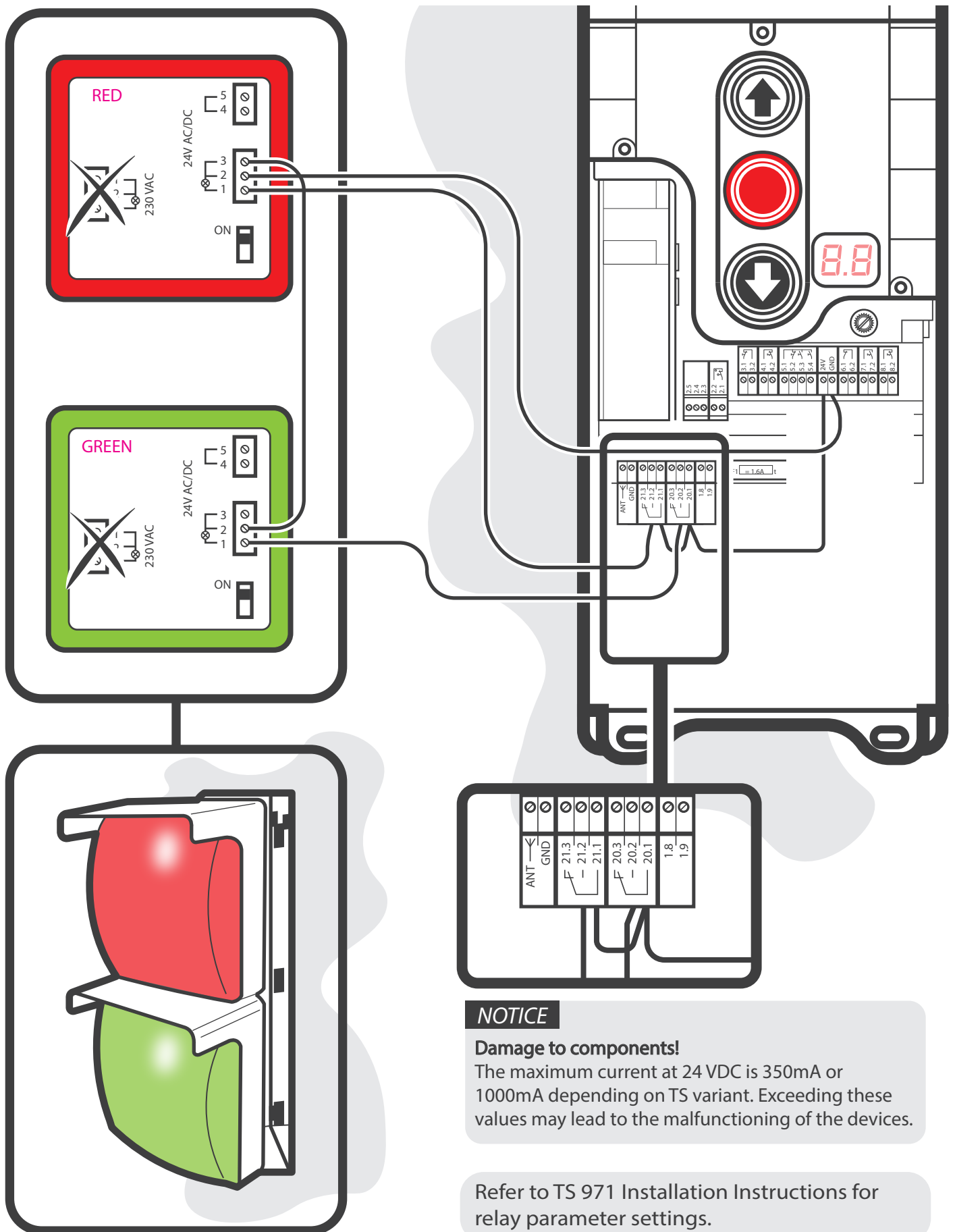

NOTICE
Damage to components!
 The maximum current at 24 VDC is 350mA or 1000mA depending on TS variant. Exceeding these values may lead to the malfunctioning of the devices.

Refer to TS 971 Installation Instructions for relay parameter settings.

▪ Red/Green Traffic Indicator (230VAC)

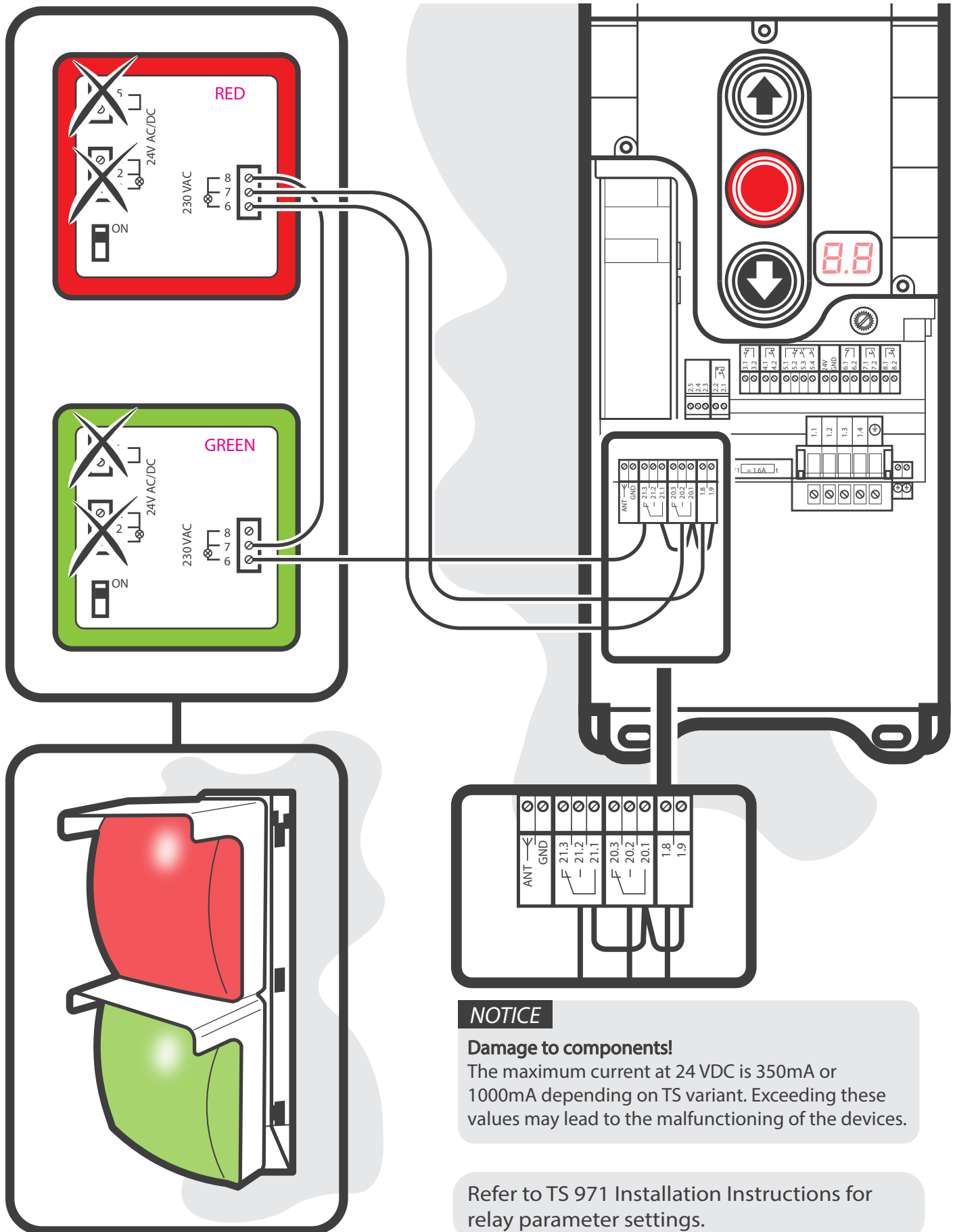

NOTICE
Damage to components!
 The maximum current at 24 VDC is 350mA or 1000mA depending on TS variant. Exceeding these values may lead to the malfunctioning of the devices.

Refer to TS 971 Installation Instructions for relay parameter settings.

1No. LZR Widescan

- With auxiliary PSU

i NOTE

A safety edge and photocell are required to protect against impact from the doors leading edge when an LZR Widescan is in use.

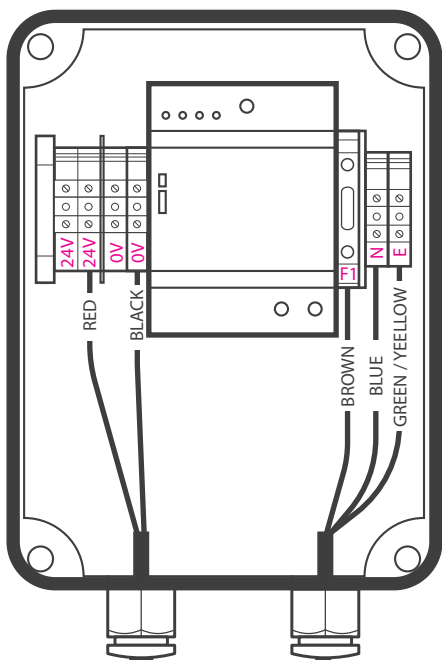

i NOTE

Neutral required on site.

i NOTE

Test input available for the LZR Widescan if required.

- When test input not in use, 24VDC is supplied via Red and Black wires.

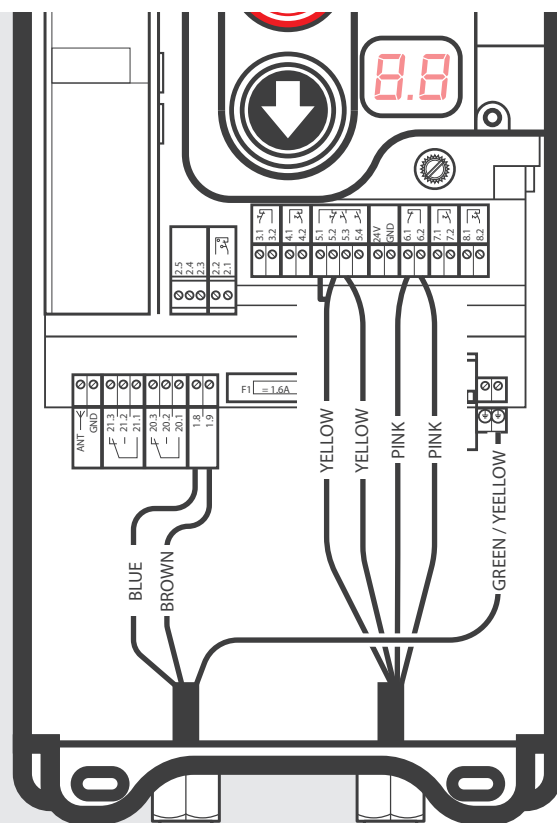

Download the LZR Widescan App

RED	12 - 24	SUPPLY
BLACK	VAC/DC	
YELLOW	N/O	OUTPUT 1
YELLOW	COM	
PINK	N/C	OUTPUT 2
PINK	COM	
BLUE	12 - 24	TEST
BLUE	VAC/DC	
GREEN		RELAY
WHITE/GREEN		
GREEN/GREY		

i NOTE

Read the LZR WIDESCAN instructions for essential installation and testing procedures.

1No. LZR100 and 110 Industrial Laser Safety Sensor



▪ With auxiliary PSU

i NOTE

A safety edge and photocell are required to protect against impact from the doors leading edge when 1No. LZR is in use.

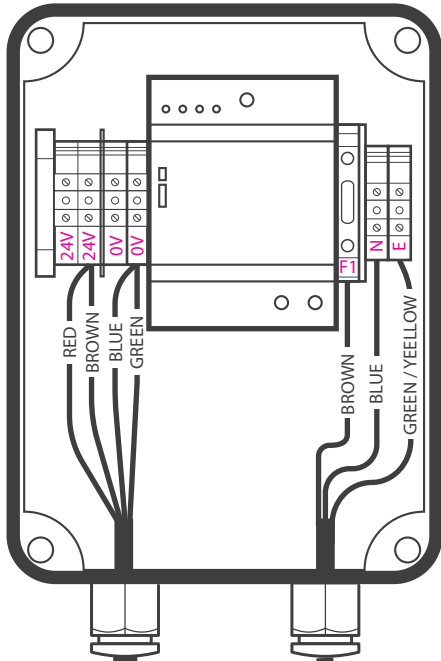

i NOTE

Neutral required on site.

i NOTE

iRemote required for installation.

i NOTE

Ignore connections to 5.2 and 5.3 when virtual push button not required.

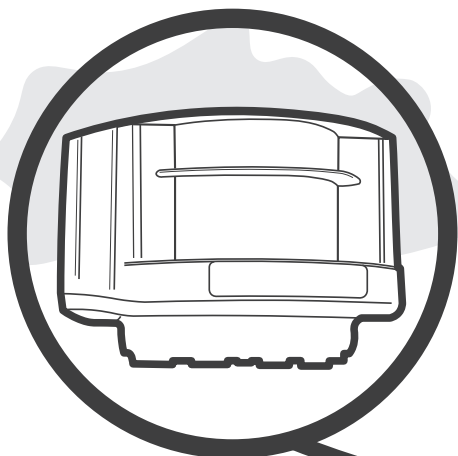
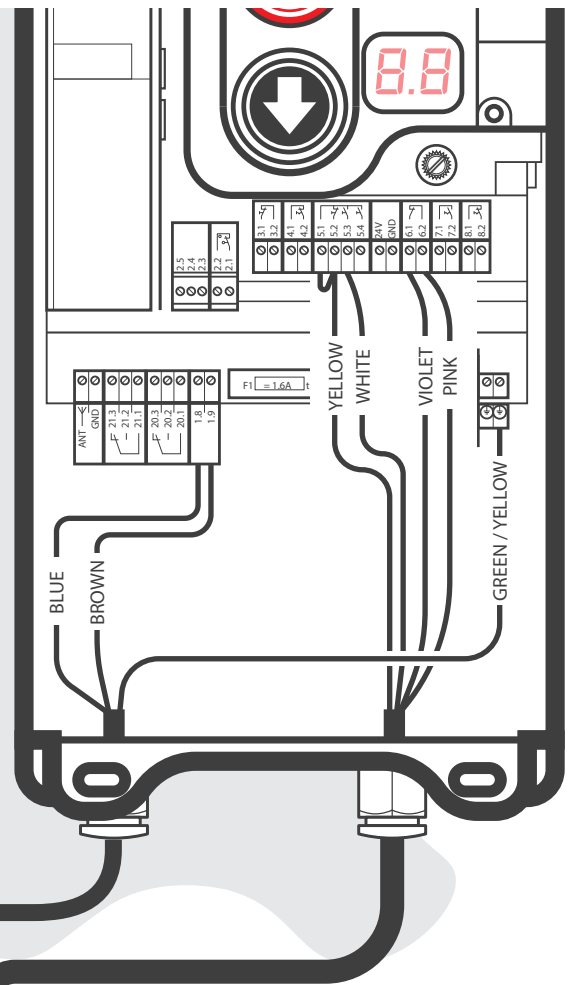

i NOTE

Door control without test:
Connect Red and Blue wires into the power supply.

- NO POLARITY

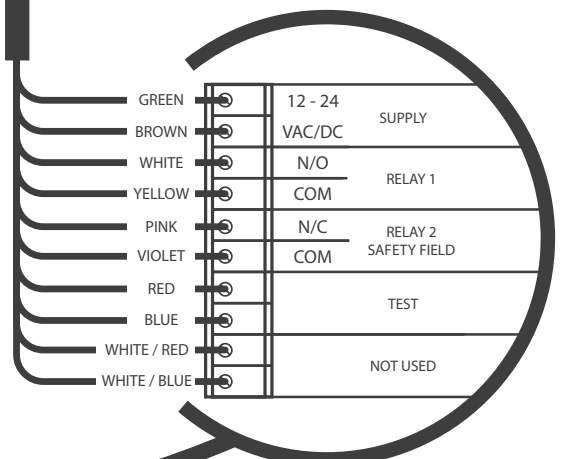

i NOTE

Read the LZR100 or 110 instructions for essential installation and testing procedures.

2No. LZR100 and 110 Industrial Laser Safety Sensor - With auxiliary PSU (CC61219)



i NOTE

Neutral required on site.

i NOTE

iRemote required for installation.

i NOTE

Ignore connections to 5.2 and 5.3 when virtual push button not required.

i NOTE

2No. LZR sensors can be used instead of a safety edge and is certified as a Type 'E' device according to BS EN 12453 providing they are correctly mounted following the LZR installation instructions.

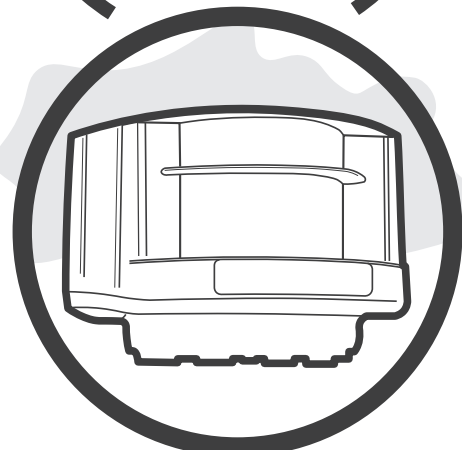
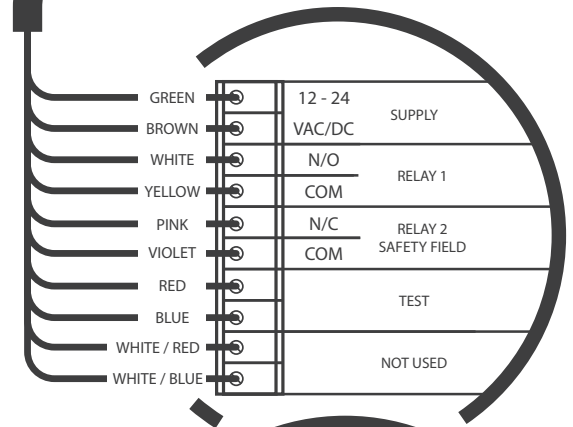
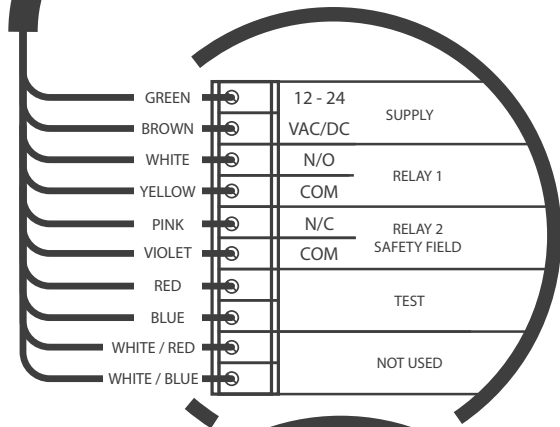
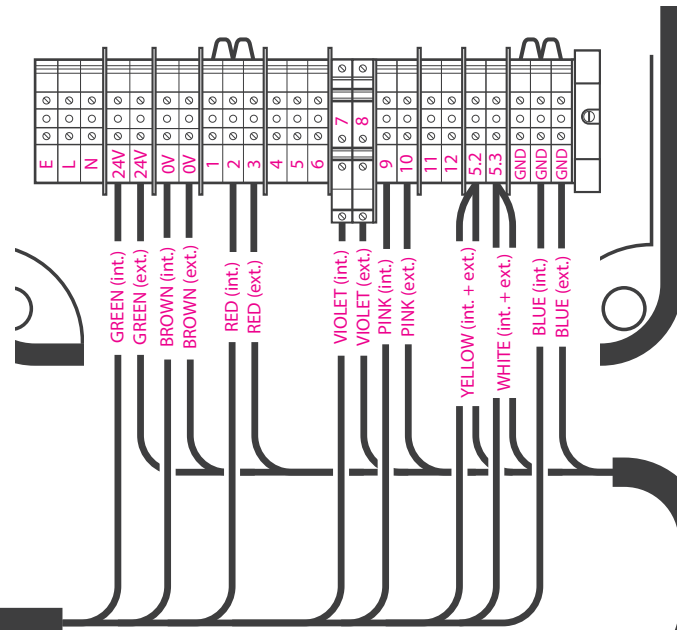

INTERNAL

i NOTE

Door control without test:
Connect Red and Blue wires into the power supply.
▪ NO POLARITY

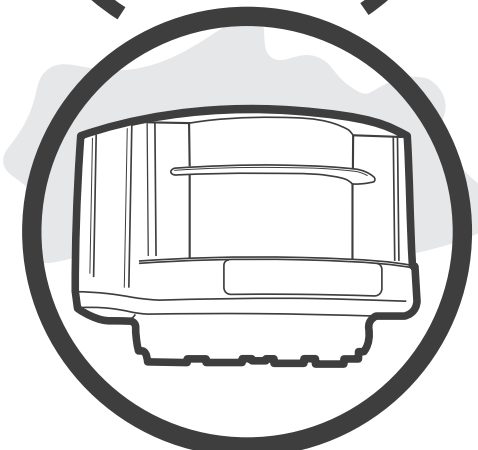

EXTERNAL

i NOTE

Read the LZR100 or 110 instructions for essential installation and testing procedures.

2No. LZR100 and 110 Industrial Laser Safety Sensor



- With auxiliary PSU (CC61219)

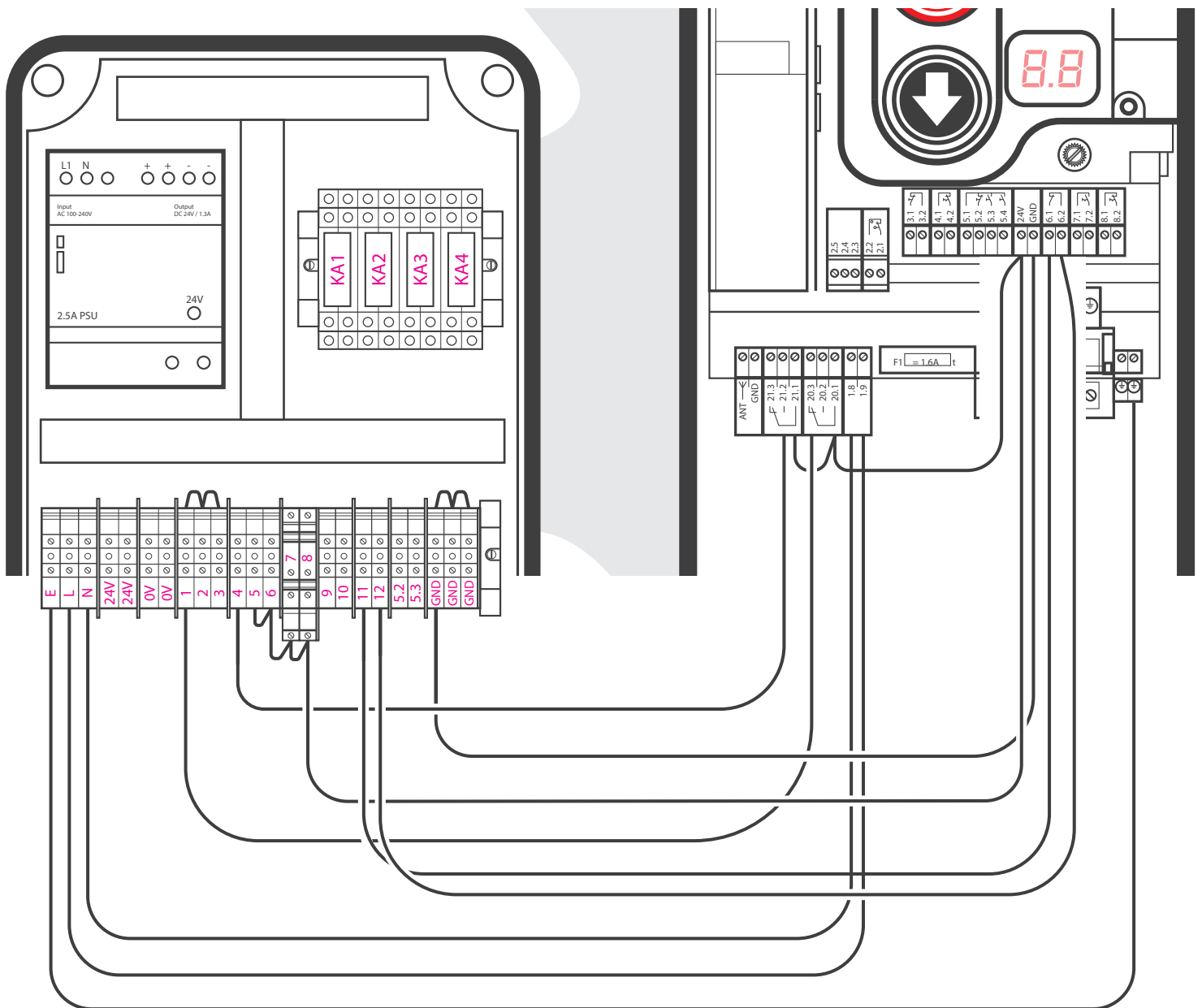

Parameter Settings:

- Set parameter **2.7** to **1.4** (Light Curtain Test)
- Set parameter **2.8** to **.7** (Energise at Top Limit)

i NOTE
Read the LZR100 or 110 instructions for essential installation and testing procedures.

1No. CONDOR & CONDOR XL



Industrial Motion & Presence Sensor

i NOTE

A safety edge and photocells are required to protect against impact from the doors leading edge when motion sensors are in use.

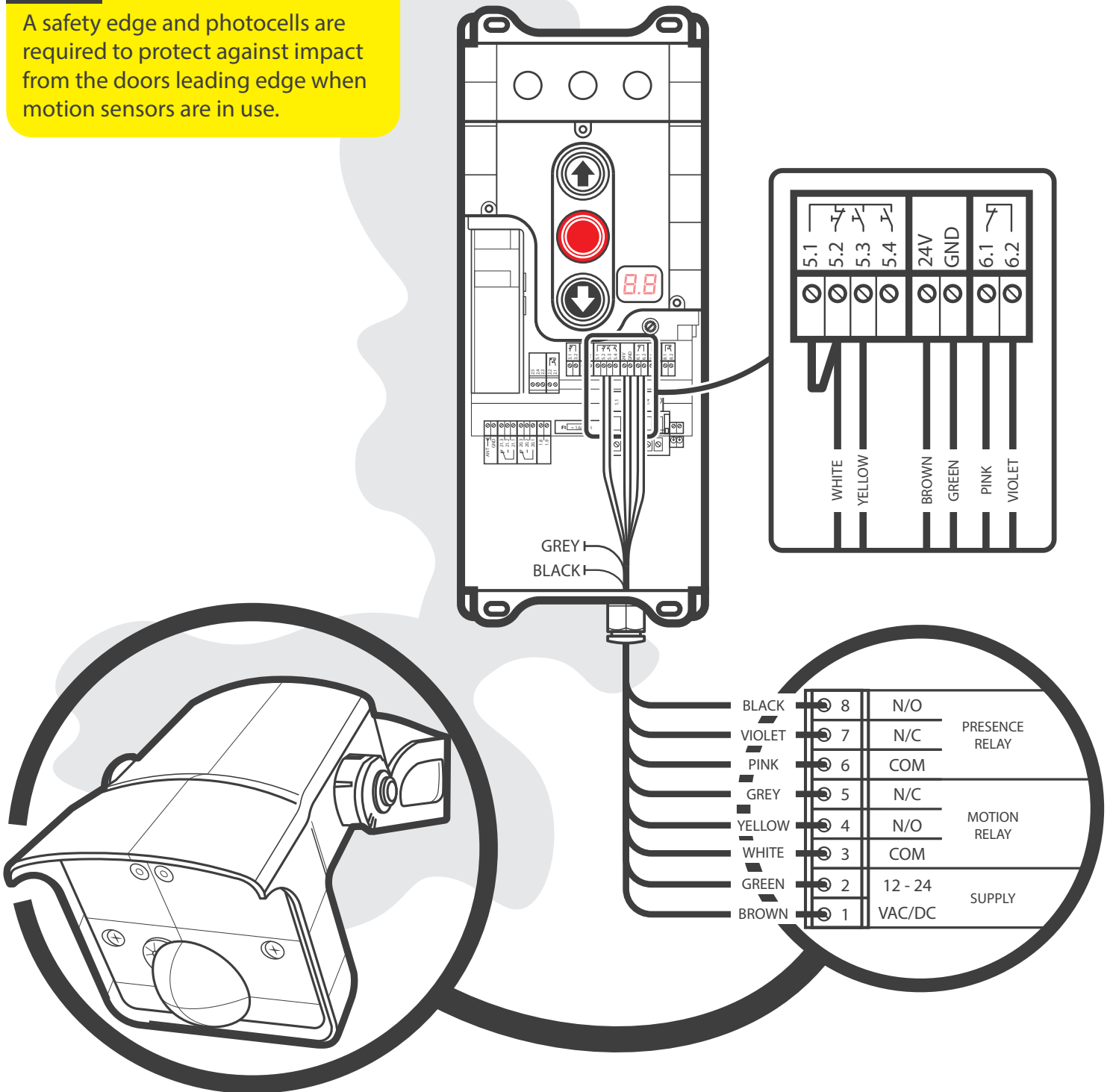

i NOTE

Consult the manufacturer's instructions for setting and operating the sensor.

1No. FALCON & FALCON XL

▪ Industrial Motion Sensor



i NOTE

A safety edge and photocells are required to protect against impact from the doors leading edge when motion sensors are in use.

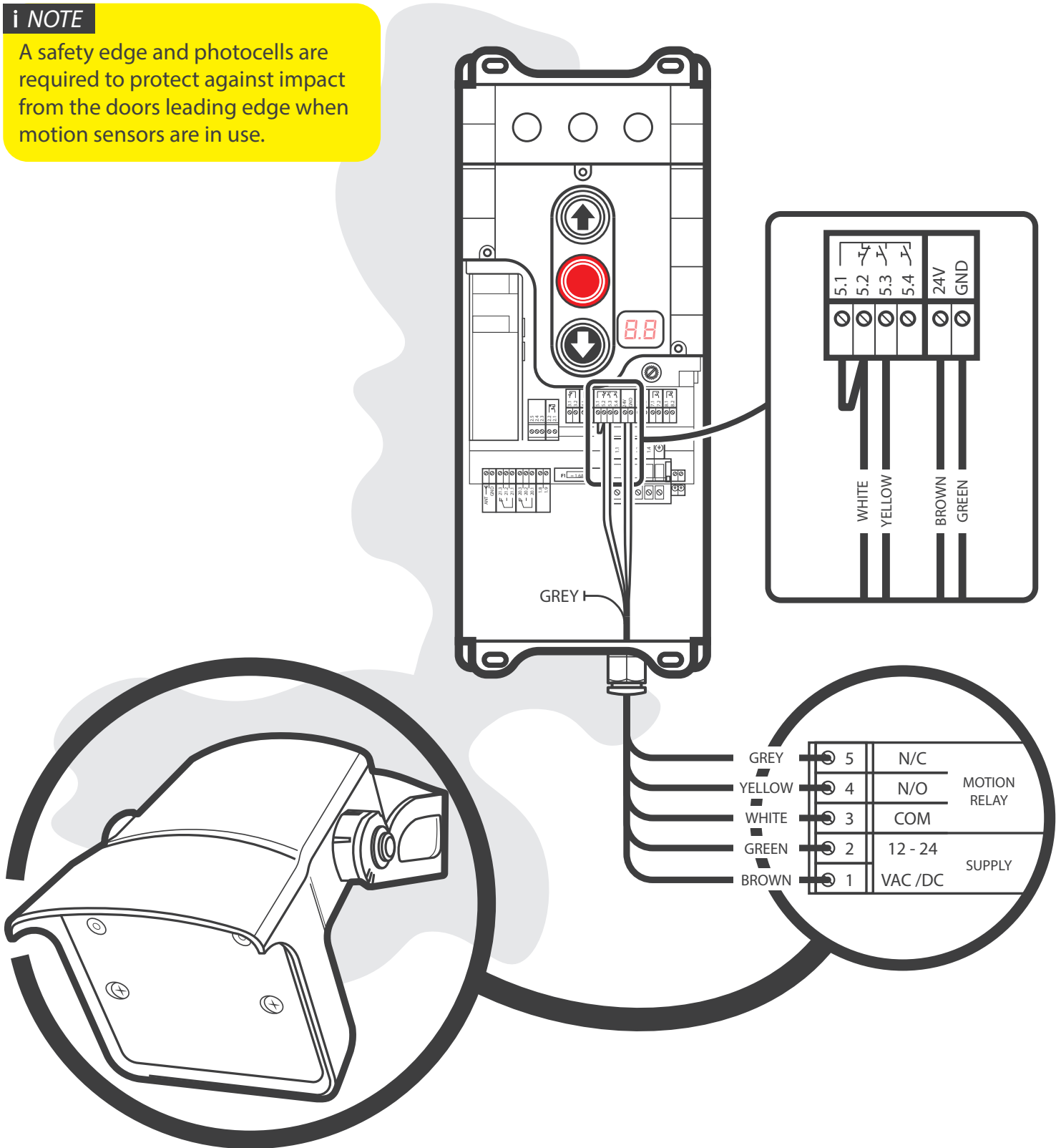

i NOTE

Consult the manufacturer's instructions for setting and operating the sensor.

The TS 971 provides a 24VDC power supply for control accessories such as photocells, Falcon, etc.

The maximum permitted load is either 350mA or 1000mA, depending on the variant of TS 971.

Example:

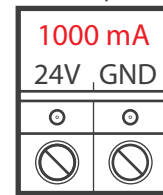

To identify the variant of TS 971, refer to the 24V and GND terminals on the panel - this will denote the maximum permitted load.

Take care not to overload the 24VDC power supply. This may cause the TS 971 to malfunction or stop operation. If the 24VDC supply is short-circuited the red point in the display goes out.

The below table shows the typical power consumption of common GfA 24VDC accessories

24VDC Control Accessories

Part No.	Description	Power Consumption
GF/RAY-LGxxxx/OSE	Light Curtain	100mA
PES/9R	Polarised Reflective Photocell (9m)	40mA (per sensor)
PES/30T	Through-beam transmitter & receiver (30m)	40mA (per sensor)
CALOOPKIT	Loop Detector PCB	40mA
Falcon inc. XL	Industrial Motion Sensor	80mA
Condor inc. XL	Industrial Motion & Presence Sensor	150mA
LZR 100 & 110	Laser Safety Sensor	200mA
VR/R2E	Radio Control Receiver	24mA
VR/XPL5	Multi-User Receiver	90mA
CA28030	Visual Warning Device Amber Beacon	80mA
CA235-966	Visual Warning Device Blue Beacon	80mA
CA6695427	Flashing Visual Warning Device	30mA
JE419130/B	Red & Green Traffic Light	60mA (without flashing)
JE419130	Red & Green Traffic Light (Dual Voltage)	120mA

In most cases the power supply will support a number 24 VDC control accessories but due to the large in-rush current required by the Falcon and Condor sensors, a separate power supply may be required if more than 1 unit is fitted.

The LZR Laser sensors also demand a high peak current (1.8A) when powered on and should be provided with a separate power supply.

i NOTE

External PSU only required when using the 350mA TS 971 variant.



Part No.	Description	Voltage	24VDC Output
CC60519	Aux. PSU	415V - 24VAC	2000mA
CC60787	Aux. PSU	230V - 24VAC	2000mA
CC60951	Aux. PSU	230VAC - 24VDC	400mA
CC61219	LZR Self Test Unit	230VAC - 24VDC	2500mA
CC60809	2.5A PSU 230/24Vdc	230VAC - 24VDC	2500mA

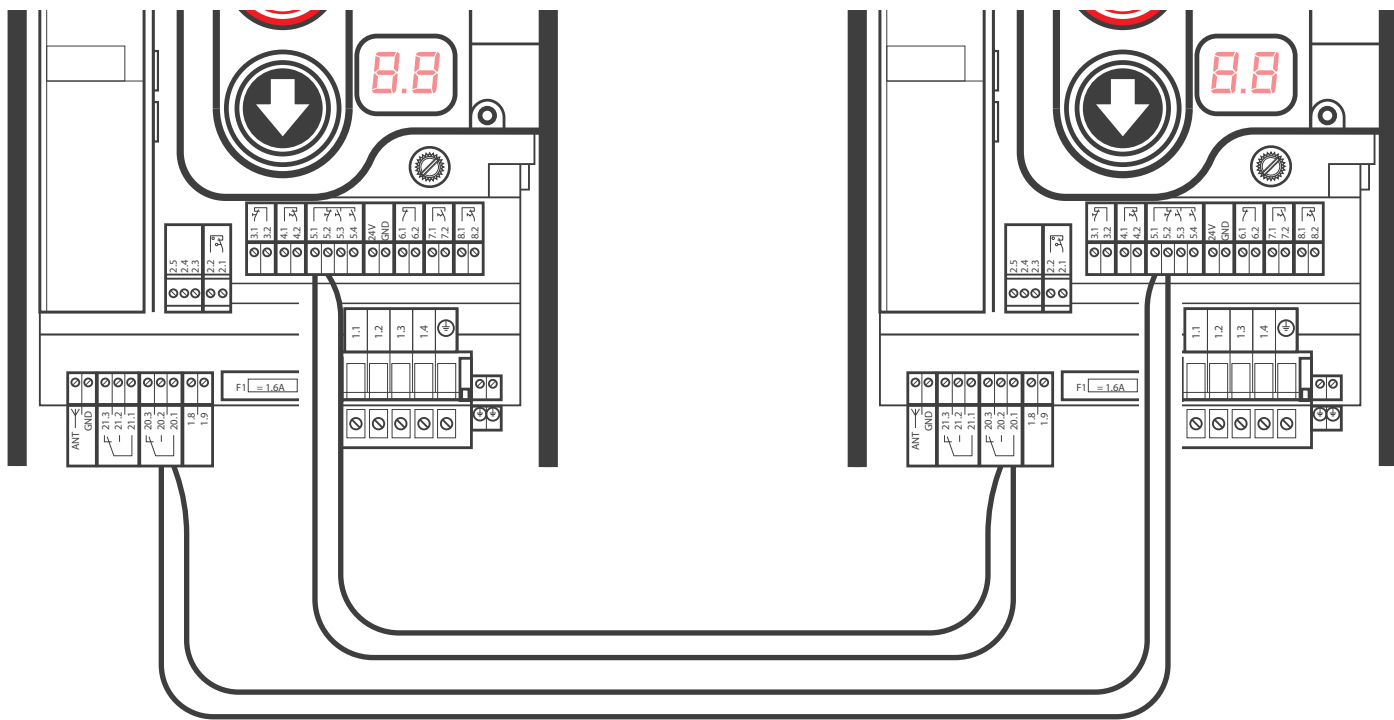

▪ Set Parameter 2.7 on both panels to .8.

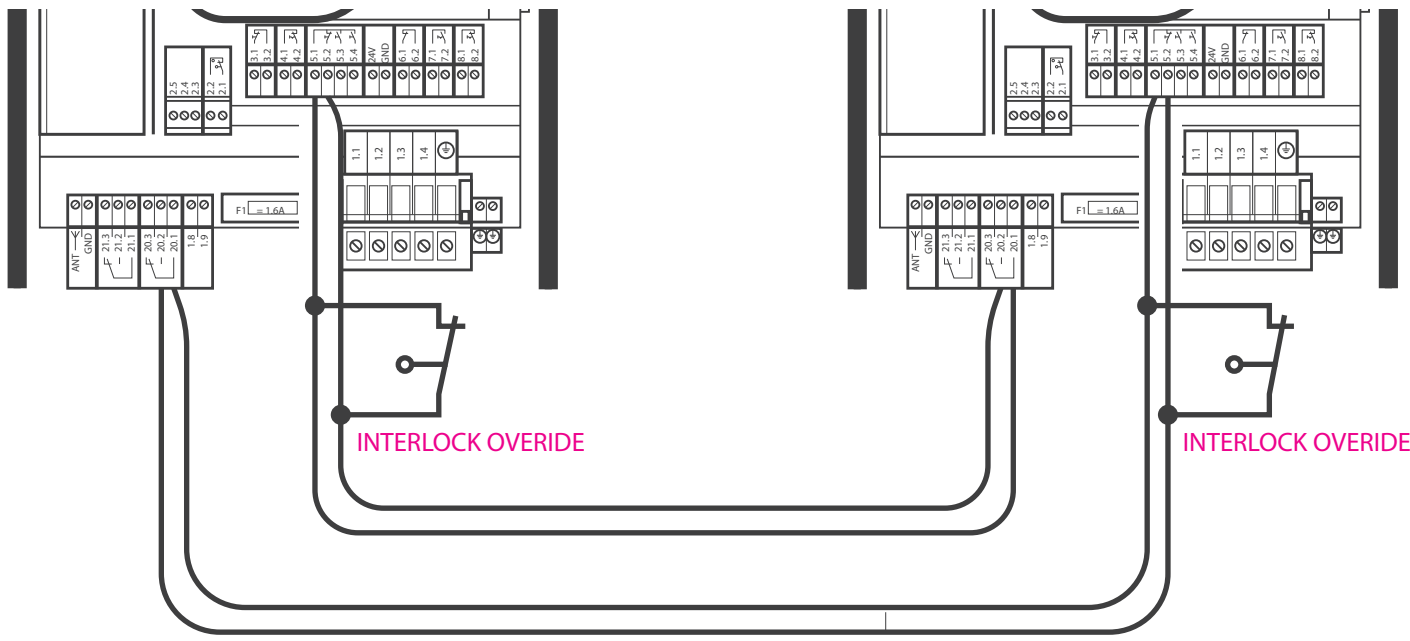

Interlocking both TS 971's only allows one door to be opened at a time.

